

A Division of Systems, LLC

POWERAMP

Premium Loading Dock Systems

PowerStop[®]

Vehicle Restraint

Owner's/User's Manual

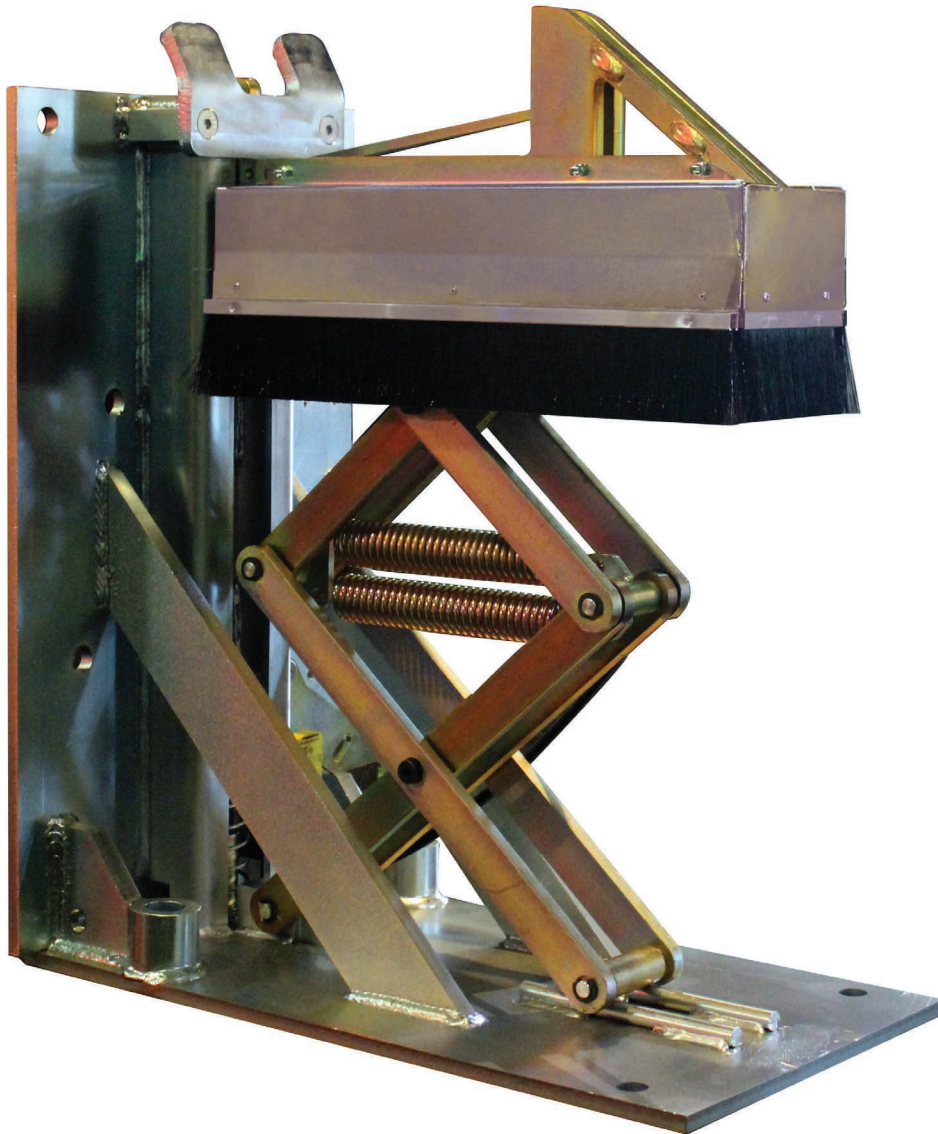

Poweramp • Division of Systems, LLC • W194 N11481 McCormick Drive • Germantown, WI 53022

800.643.5424 • fax: 262.255.5917 • www.poweramp.com • techservices@poweramp.com

Printed in U.S.A.

© 2020 Systems, LLC - All Rights Reserved

Manual No. 4111-0014

Apr. 2020

Table of Contents

	Page		Page
Precautions		Maintenance	
Recognize Precautionary Information.....	1	Maintenance Precautions	25
General Operational Precautions	1	Periodic Maintenance	26
Operational Precautions	2		
Safety Decals	4	Adjustments	
Placard.....	4	Adjust Dock Leveler and Vehicle Restraint	
Owner's/User's Responsibilities.....	6	Interlock.....	28
Introduction		Troubleshooting	
General Information	8	PowerStop Troubleshooting	36
Component Identification	9		
		Parts	
Installation		RIG Sensor Assembly.....	33
Installation Precautions.....	10	PowerStop M Components.....	34
Concrete Dock Face.....	11	PowerStop A Components	36
Low Pit Floor.....	12	Scissor Assembly	38
Driveway Mount.....	13	Cantilever Brackets.....	39
Cantilevered Dock	14	Powerpack Assembly	40
PowerStop Mechanical Operating Wand		Hydraulic Combo Valve Block	42
Bracket	15	Outside Light Assembly	43
PowerStop Automatic Powerpack.....	16	Signs.....	44
Install Control Panel and Wiring.....	18		
Install Outside Light Assembly and Signs	19	Miscellaneous	
Placard Installation Instructions.....	20	Customer Information.....	45
Put New Restraint Into Service.....	21	Warranty	Back Cover
Operation			
Operational Precautions.....	22		
Operation - Normal.....	22		
Operation - Bypass	23		
Multi-Colored & Outside Light Sequence			
Charts	24		

PRECAUTIONS

Recognize Precautionary Information

Safety-Alert Symbol



The Safety-Alert Symbol is a graphic representation intended to convey a safety message without the use of words. When you see this symbol, be alert to the possibility of death or serious injury. Follow the instructions in the safety message panel.

DANGER

The use of the word DANGER signifies the presence of an extreme hazard or unsafe practice which will most likely result in death or severe injury.

WARNING

The use of the word WARNING signifies the presence of a serious hazard or unsafe practice which could result in death or serious injury.

CAUTION

The use of the word CAUTION signifies possible hazard or unsafe practice which could result in minor or moderate injury.

NOTICE

The use of the word NOTICE indicates information considered important, but not hazard-related, to prevent machine or property damage.

SAFETY INSTRUCTIONS

Indicates a type of safety sign, or separate panel on a safety sign, where safety-related instructions or procedures are described.

General Operational Precautions



Read and understand the Owner's/User's Manual and become thoroughly familiar with the equipment and its controls before operating the equipment.

Never operate equipment while a safety device or guard is removed or disconnected.

Never remove DANGER, WARNING, or CAUTION signs, Placards or Decals on the equipment unless replacing them.

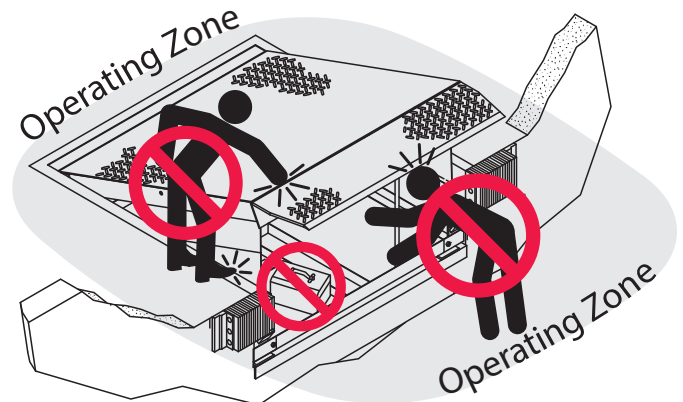

Figure 1

Do not start the equipment until all unauthorized personnel in the area have been warned and have moved outside the operating zone (see Figure 1).

Remove any tools or foreign objects from the operating zone before starting.

Keep the operating zone free of obstacles that could cause a person to trip or fall.



WARNING: This product can expose you to chemicals including lead, which are known to the State of California to cause cancer or birth defects or other reproductive harm. For more information go to www.P65Warnings.ca.gov

PRECAUTIONS

Operational Precautions



Learn the safe way to operate this equipment. Read and understand the manufacturer's instructions. If you have any questions, ask your supervisor.

DANGER



Stay clear of dock leveling device when transport vehicle is entering or leaving area.



Do not move or use the dock leveling device if anyone is under or in front of it.

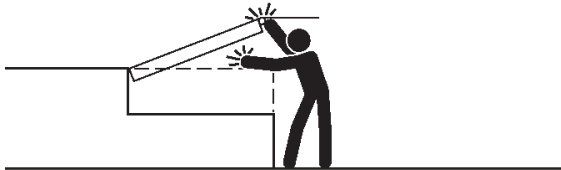

Keep hands and feet clear of pinch points. Avoid putting any part of your body near moving parts.

WARNING



Chock/restrain all transport vehicles. Never remove the wheel chocks or release the restraining device until loading or unloading is finished, and transport driver has been given permission to drive away.



Do not use a broken or damaged dock leveling device or restraining device. Make sure proper service and maintenance procedures have been performed before using.



Make sure lip overlaps onto transport vehicle bed at least 4 in. (102 mm).

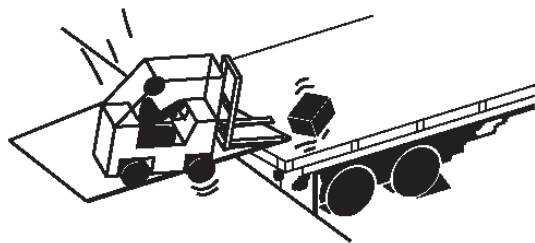

Keep a safe distance from both side edges.

Operational Precautions

! WARNING

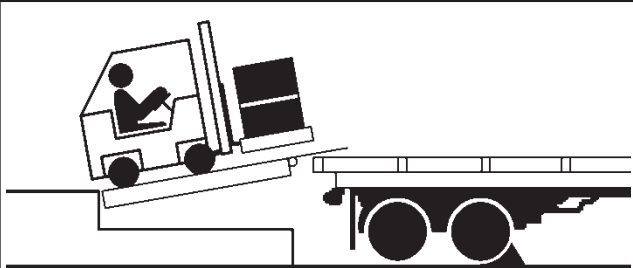

Do not use dock leveling device if transport vehicle is too high or too low.

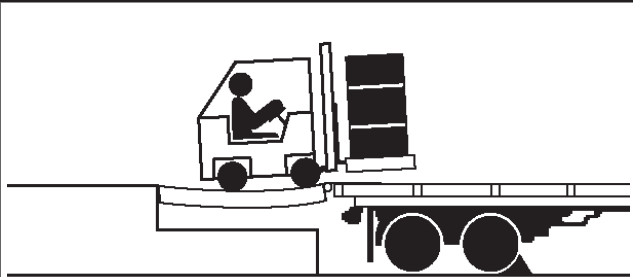

Do not overload the dock leveling device.



Do not operate any equipment while under the influence of alcohol or drugs.

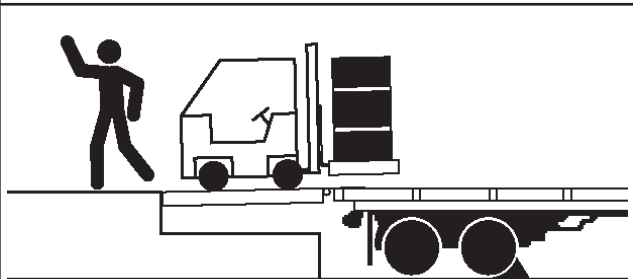

Do not leave equipment or material unattended on dock leveling device.

PRECAUTIONS

Safety Decals

PowerStop-M



Serial Tag

Scan to view
owners manuals
online.

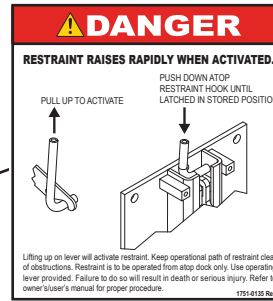
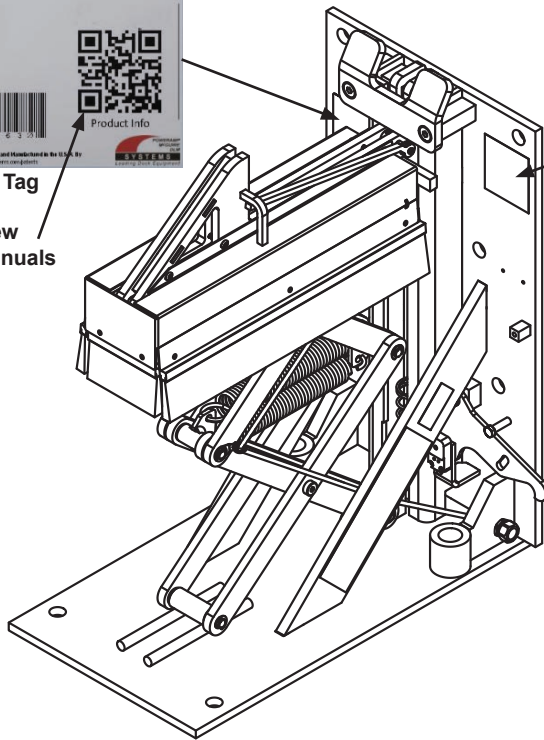

1751-0135

PowerStop-AAL



1751-1252



1751-0149



Serial Tag

Scan to view
owners manuals
online.

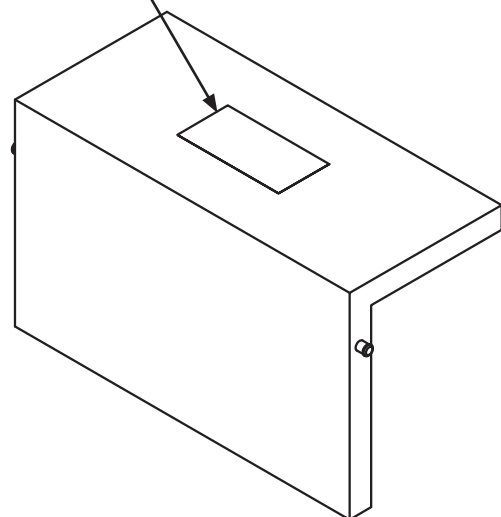
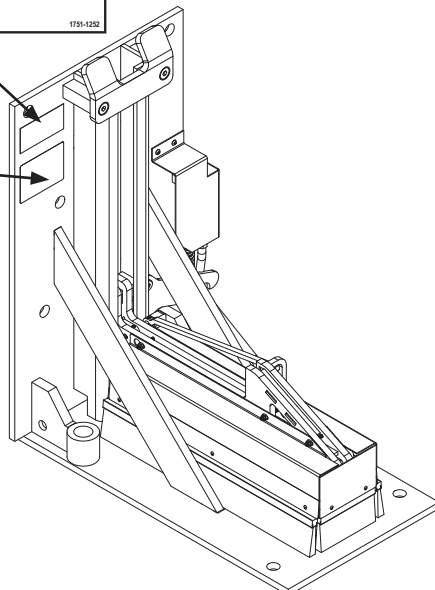
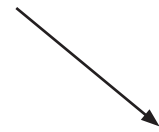

Figure 2

Placards

Restraints without
Light Communication
Package



DANGER

OPERATING INSTRUCTIONS

VEHICLE RESTRAINTS

Use for PowerStop or StopTite without Light Communication System

1. Before using the vehicle restraint:
 - Remove any debris, snow, or ice that may obstruct vehicle restraint operation.
 - Alert personnel in the area of potential vehicle restraint operation and ensure area is clear.
 - Operate the vehicle restraint through one complete cycle inspecting it for proper operation and light sequence. Advise maintenance personnel of any damage or improper operation immediately. Remove all malfunctioning or damaged vehicle restraints from service using approved lockout/tagout procedures.
2. Before attempting to restrain a transport vehicle:
 - Verify that transport vehicle is positioned squarely against dock bumpers.
 - Inspect the transport vehicle's rear impact guard (RIG). Damaged or missing RIGs, lift gates or other obstructions may not allow the vehicle restraint to securely capture the RIG. Wheel chocks must be used whenever the ability for the vehicle restraint to capture the RIG is in question. **(NOTE: The transport vehicle's suspension and load condition will affect trailer height.)**
3. After activating vehicle restraint:
 - Verify that the transport vehicle's RIG has been restrained successfully. In the event this cannot be determined, use wheel chocks in addition to restraint.
4. Maintenance or service must be performed by authorized personnel only. Follow approved lockout/tagout procedures.

FAILURE TO FOLLOW THESE INSTRUCTIONS WILL RESULT IN DEATH OR OTHER SERIOUS INJURY.

RELEASE BAR

RELEASE LATCH

ENGAGE RESTRAINT

1. Open overhead door and visually check that transport vehicle is positioned squarely against dock bumpers and has a RIG bar.
2. Using release bar, pull upward on release latch until restraint is released.
3. Visually inspect that RIG bar has been restrained.

RELEASE BAR

RELEASE LATCH

RELEASE RESTRAINT

1. To release restraint push down on restraint arm with release bar until restraint is completely stored. **(Note: Restraint is completely stored when release latch engages restraint arm.)**

BY-PASS

1. If restraint is unable to secure transport vehicle's RIG due to damaged or missing RIG, use wheel chocks to secure transport vehicle at the dock.
2. Return restraint to stored position.
3. Loading/unloading may proceed with caution.

Scan to view our owner's/user's manuals online.
www.LoadingDockSystems.com

1.800.643.5424

Call for additional placards, or manuals, or with questions regarding proper use, maintenance, and repair of dock leveler.

POWERAMP
MIGRORE
DLM
SYSTEMS
Loading Dock Equipment

WARNING: CANCER AND REPRODUCTIVE HARM
www.P65Warnings.ca.gov

1751-1296 Rev A

1751-1296

Restraints with Light
Communication
Package

DANGER

OPERATING INSTRUCTIONS

VEHICLE RESTRAINTS

Use for PowerStop and StopTite series

1. Before using the vehicle restraint:
 - Remove any debris, snow, or ice that may obstruct vehicle restraint operation.
 - Alert personnel in the area of potential vehicle restraint operation and ensure area is clear.
 - Operate the vehicle restraint through one complete cycle inspecting it for proper operation and light sequence. Advise maintenance personnel of any damage or improper operation immediately. Remove all malfunctioning or damaged vehicle restraints from service using approved lockout/tagout procedures.
2. Before attempting to restrain a transport vehicle:
 - Verify that transport vehicle is positioned squarely against dock bumpers.
 - Inspect the transport vehicle's rear impact guard (RIG). Damaged or missing RIGs, lift gates or other obstructions may not allow the vehicle restraint to securely capture the RIG. Wheel chocks must be used whenever the ability for the vehicle restraint to capture the RIG is in question. **(NOTE: The transport vehicle's suspension and load condition will affect trailer height.)**
3. After activating vehicle restraint:
 - Verify that the transport vehicle's RIG has been restrained successfully. In the event this cannot be determined, use wheel chocks in addition to restraint.
 - If equipped with a light communication system, load and unload on GREEN light only.
4. Maintenance or service must be performed by authorized personnel only. Follow approved lockout/tagout procedures.

FAILURE TO FOLLOW THESE INSTRUCTIONS WILL RESULT IN DEATH OR OTHER SERIOUS INJURY.

RELEASE BAR

RELEASE LATCH

ENGAGE RESTRAINT

1. Open overhead door and visually check that transport vehicle is positioned squarely against dock bumpers and has a RIG bar. Inside light is RED and outside light is GREEN (if equipped with lights).
2. **(Powered Restraints)** Press the ENGAGE button to activate restraint. **(Manual Restraints)** Using release bar, pull upward on release latch until restraint is released.
3. Visually inspect that RIG bar has been restrained. If not see BY-PASS operation.
4. **(Automatic Light Controls)** When RIG is secured inside light is GREEN and outside light is RED. **(Manual Light Controls)** Once RIG is secured press DOCK ALERT STATUS button. Inside light is GREEN and outside light is RED.

RELEASE BAR

RELEASE LATCH

RELEASE RESTRAINT

1. **(Powered Restraints)** To release restraint press the RELEASE button. When safely stored inside light is RED and outside light is GREEN. **(Manual Restraints)** To release restraint push down on restraint arm with release bar until restraint is completely stored. **(Note: Restraint is completely stored when release latch engages restraint arm.)**
2. **(Automatic Light Controls)** When safely stored inside light is RED and outside light is GREEN. **(Manual Light Controls)** Once RIG is secured press DOCK ALERT STATUS button. Lights change to RED inside and GREEN outside.

BY-PASS

1. If restraint is unable to secure transport vehicle's RIG due to damaged or missing RIG, use wheel chocks to secure transport vehicle at the dock.
2. **(Powered Restraint)** After restraint automatically returns to stored position. Press ENTER button to activate BY-PASS.
 - Can also change Operating Mode through menu display.**(Manual Restraint)** Return restraint to stored position. Press DOCK ALERT STATUS button.
3. Inside light is GREEN/AMBER and outside light is RED.
4. Loading/unloading may proceed with caution.

BY-PASS RESET (RETURN TO NORMAL OPERATION)

1. When loading/unloading is complete remove wheel chocks.
2. **(Powered Restraint)** Press the RELEASE button to reset lights. **(Manual Restraint)** Press DOCK ALERT STATUS button.
3. Lights change to RED inside and GREEN outside.

Scan to view our owner's/user's manuals online.
www.LoadingDockSystems.com

1.800.643.5424

Call for additional placards, or manuals, or with questions regarding proper use, maintenance, and repair of dock leveler.

POWERAMP
MIGRORE
DLM
SYSTEMS
Loading Dock Equipment

WARNING: CANCER AND REPRODUCTIVE HARM
www.P65Warnings.ca.gov

1751-1265 Rev A

1751-1265

4111-0014 — Apr. 2020
© 2020 Systems, LLC

5

OWNER'S/USER'S RESPONSIBILITIES

- 1) The manufacturer shall provide to the initial purchaser and make the following information readily available to the owners/users and their agents, all necessary information regarding Safety Information, Operation, Installation and Safety Precautions, Recommended Initial and Periodic Inspections Procedures, Planned Maintenance Schedule, Product Specifications, Troubleshooting Guide, Parts Break Down, Warranty Information, and Manufacturers Contact Information.
- 2) The owner/user should recognize the inherent dangers of the interface between the loading dock and the transport vehicle. The owner/user should, therefore, train and instruct all operators in the safe operation and use of the restraining device in accordance with manufacturer's recommendations and industry standards. Effective operator training should also focus on the owner's/user's company policies, operating conditions and the manufacturer's specific instructions provided with the restraining device. Maintaining, updating and retraining all operators on safe working habits and operation of the equipment, regardless of previous experience, should be done on a regular basis and should include an understanding and familiarity with all functions of the equipment. Owners/users shall actively maintain, update and retrain all operators on safe working habits and operations of the equipment.
- 3) When selecting a restraining device, it is important to consider not only present requirements but also future plans and any possible adverse conditions, environmental factors or usage. The owners/users shall provide application information to the manufacturer to receive recommendations on appropriate equipment specifications.
- 4) The owner/user must see all nameplates, placards, decals, instructions and posted warnings are in place and legible and shall not be obscured from the view of the operator or maintenance personnel for whom such warnings are intended for. Contact manufacturer for any replacements.
- 5) Modifications or alterations of restraining devices shall be made only with prior written approval from the original manufacturer. These changes shall be in conformance with all applicable provisions of the MH30.3 standard and shall also satisfy all safety recommendations of the original equipment manufacturer of the particular application.
- 6) An operator training program should consist of, but not necessarily be limited to, the following:
 - a) Select the operator carefully. Consider the physical qualifications, job attitude and aptitude.
 - b) Assure that the operator reads and fully understands the complete manufacturer's owners/users manual.
 - c) Emphasize the impact of proper operation upon the operator, other personnel, material being handled, and equipment. Cite all rules and why they are formulated.
 - d) Describe the basic fundamentals of the restraining device and components design as related to safety, e.g., mechanical limitation, stability, functionality, etc.
 - e) Introduce the equipment. Show the control locations and demonstrate functions. Explain how they work when used properly and maintained as well problems when they are used improperly.
 - f) Assure that the operator understands nameplate data, placards and all precautionary information appearing on the restraining device.
 - g) Supervise operator practice of equipment.
 - h) Develop and administer written and practical performance tests. Evaluate progress during and at completion of the course.
 - i) Administer periodic refresher courses. These may be condensed versions of the primary course and include on-the-job operator evaluation.
- 7) It is recommended that the transport vehicle is positioned as close as practical to the dock leveling device and in contact with both bumpers. When an industrial vehicle is driven on or off a transport vehicle during loading and unloading operations, the transport vehicle parking brakes shall be applied and wheel chocks or a restraining device that provides equal or better protection of wheel chocks shall be engaged. Also, whenever possible, air-ride suspension systems should have the air exhausted prior to performing said loading and unloading operations.

OWNER'S/USER'S RESPONSIBILITIES

- 8) When goods are transferred between the loading dock and a trailer resting on its support legs/ landing gear instead of a tractor fifth wheel or converter dolly, it is recommended that an adequate stabilizing device or devices shall be utilized at the front of the trailer.
- 9) In order to be entitled to the benefits of the standard product warranty, the dock safety equipment must have been properly installed, maintained and operated in accordance with all manufacturer's recommendations and/ or specified design parameters and not otherwise have been subject to abuse, misuse, misapplication, acts of nature, overloading, unauthorized repair or modification, application in a corrosive environment or lack of maintenance. Periodic lubrication, adjustment and inspection in accordance with all manufacturers' recommendations are the sole responsibility of the owner/user.
- 10) Manufacturer's recommended maintenance and inspection of all restraining devices shall be performed in conformance with the following practices: A planned maintenance schedule program must be followed, only trained and authorized personnel shall be permitted to maintain, repair, adjust and inspect restraining devices, and only the use of original equipment manufacturer parts, manuals, maintenance instructions, labels, decals and placards or their equivalent. Written documentation of maintenance, replacement parts or damage should be kept. In the event of damage, notification to the manufacturer is required.
- 11) Restraining devices that are structurally damaged shall be removed from service, inspected by a manufacturer's authorized representative, and repaired or replaced as needed or recommended by the manufacturer before being placed back in service.

INTRODUCTION

General Information

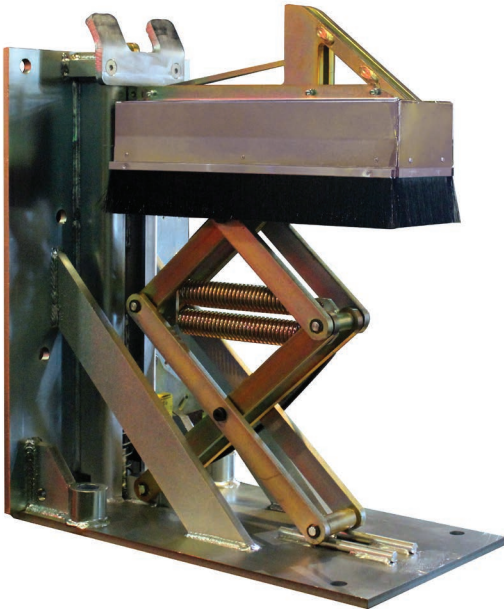

Figure 4

This manual provides current information on the PowerStop vehicle restraint (Figure 4). Due to ongoing product improvement, some parts may have changed, along with operation and troubleshooting methods. This manual describes these changes where applicable.

The PowerStop is a non-impact, self-aligning truck restraining system with restraining force in excess of 32,000 lbs.

PowerStop Mechanical models are manually operated with an operating wand. The PowerStop Automatic (hydraulic) comes equipped with an electrical control panel, which allows push button operation of the vehicle restraint functions. When combining a Poweramp Dock Leveler with a PowerStop Automatic vehicle restraint, the control panel will allow for operation of both units in the same control panel.

Each PowerStop vehicle restraint unit and control panel (if equipped) has been factory tested to ensure satisfactory operation.

To illustrate which connections are to be made in the field at installation, electrical drawings are included with each order or by contacting Systems, LLC Technical Services.

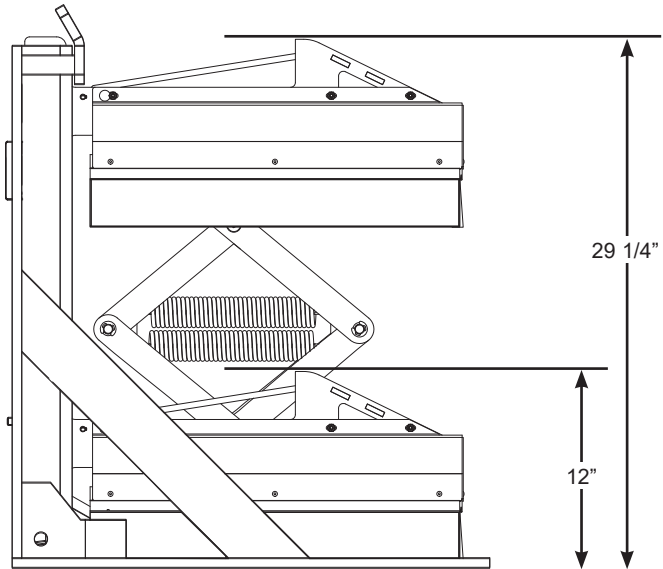

Figure 5

PowerStop vehicle restraints are available in the following models and options:

PowerStop M
Mechanical PowerStop

PowerStop MML
Mechanical PowerStop
Manual Inside and Outside Lights

PowerStop MAL
Mechanical PowerStop
Automatic Inside and Outside Lights

PowerStop AAL
Automatic PowerStop
Automatic Inside and Outside Lights

Note:

- All PowerStop models with the standard single level tall restraint hook have a service range of 12" to 29-1/4" (304.8 mm to 742.95 mm). See Figure 5.
- With the optional Low Profile restraint hook, the service range is 10" to 27-1/2" (254 mm to 698.5 mm).
- Consult the factory for operating range information for sloped approaches.

Call Systems, LLC to discuss available options to meet your specific needs.

Technical Service at 800-643-5424 or techservices@loadingdocksystems.com

Component Identification

Inspect package and all components. Report any missing or damaged items immediately and note on the shipping Bill Of Lading (BOL).

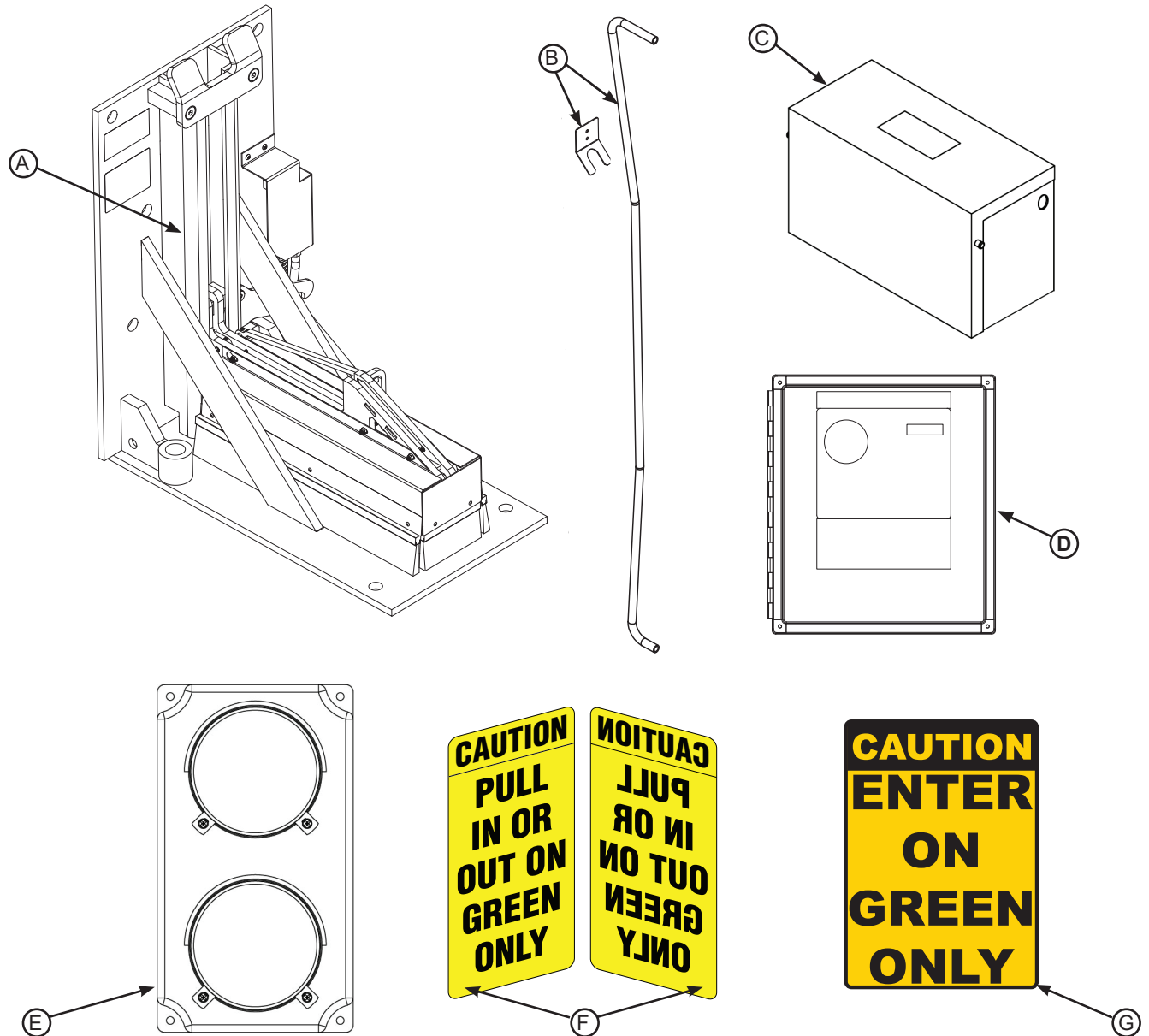

Figure 6

PowerStop M

- A — PowerStop Assembly
- B — Operating Wand & Hanger

PowerStop MML/MAL

- A — PowerStop Assembly
- B — Operating Wand & Hanger
- D — Control Box*
- E — Outside Light Assembly
- F — Outside Signs
- G — Inside Sign

PowerStop AAL

- A — PowerStop Assembly
- C — Powerpack & Hoses
- D — Control Box*
- E — Outside Light Assembly
- F — Outside Signs
- G — Inside Sign

*Control box appearance may vary depending on options.

INSTALLATION

Installation Precautions

DANGER

It is recommended and good safety practice to use an additional means to support the dock platform and lip anytime when physically working in front of or under the dock leveler. This additional means may include, but is not limited to a boom truck, fork truck, stabilizing bar or equivalent.

WARNING

Always post safety warnings and barricade the work area at dock level and ground level to prevent unauthorized use of the dock leveler before installation is complete.

A hard hat or other applicable head protection should always be worn when working under or around a dock leveler.

Always stand clear of platform lip when working in front of the dock leveler.

WARNING

DO NOT grind or weld if hydraulic fluid or other flammable liquid is present on the surface to be ground or welded.

DO NOT grind or weld if uncontained hydraulic fluid or other flammable liquid is present. Stray sparks can ignite spills or leaks near the work area. Always clean up the oil leaks and spills before proceeding with grinding or welding.

Always keep a fire extinguisher of the proper type nearby when grinding or welding.

CAUTION

Only trained installation professionals with the proper equipment should install this product.

CAUTION

In applications where adhesive anchors will be used, holes must be properly prepped and cleaned before applying adhesive into holes. Refer to adhesive instructions for further detail.

NOTICE

DO NOT connect the vehicle restraint electrical wiring and ground connections until all welding has been completed.

DO NOT ground welding equipment to any hydraulic or electrical components of the vehicle restraint. Always ground welding equipment to the vehicle restraint base, NEVER to the moving components.

Failure to follow these instructions may damage the motor, hydraulics, wiring, and/or control panel.

PowerStop Installation Overview

Concrete Dock Face (standard installation)

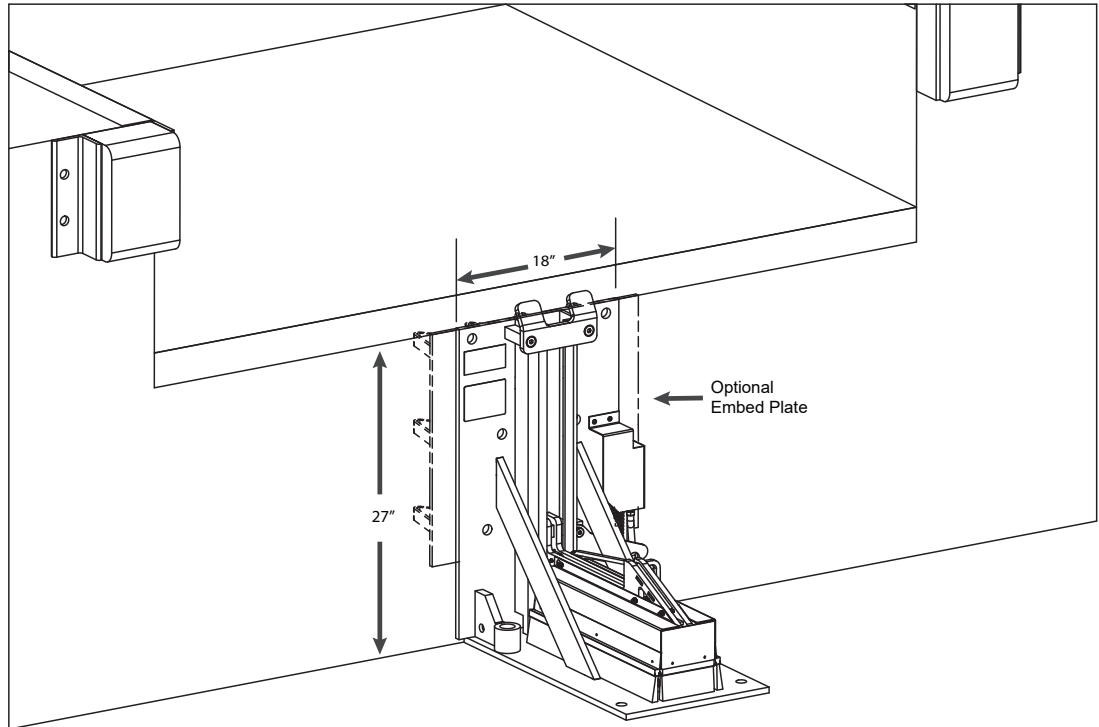

Figure 7

Note: Walls must be poured concrete, 8" thick minimum to install with wedge anchors. Concrete block or brick is not acceptable.

- **Wedge Anchors Method (Kit #2103-0003)**

Using back plate as a guide, drill six (6) holes for wedge anchors (3/4" x 5-1/4" min, see Figure 8). Install anchors. Where possible, back plate should also be welded to curb angle with 1/4" fillet weld.

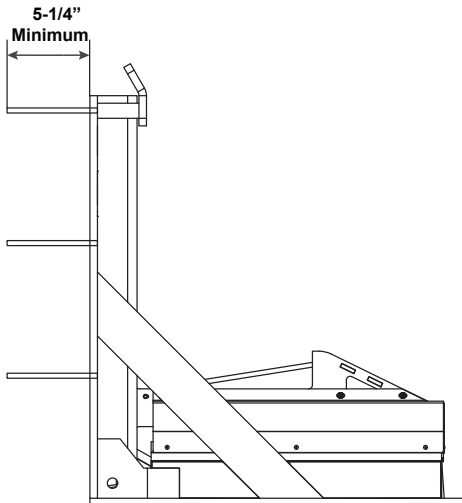

Figure 8

- **Wall Embed Method (Part #7953-0119, Figure 9)**

If optional embed plate is present, weld three sides of PowerStop back plate to the embed mounting plate with ten (10) 4" long, 1/4" fillet welds. See Figure 7.

Where possible, back plate should also be welded to curb angle with 1/4" fillet weld.

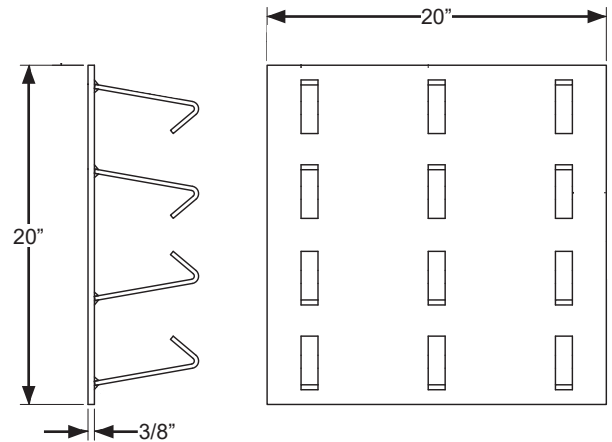

Figure 9

INSTALLATION

Low Pit Floor (distance from pit floor to drive under 24")

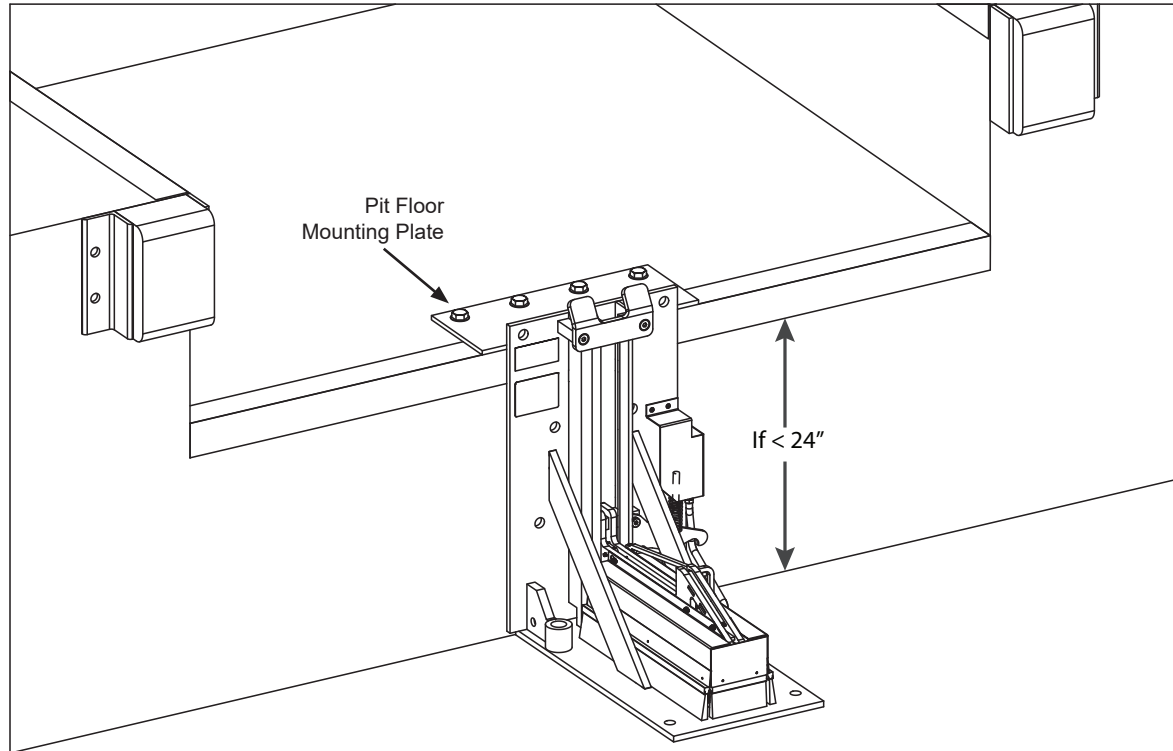

Figure 10

Anchor pit floor mounting plate (minimum 3/8" x 20"W x 8"D, Part #9414-0056, Figure 10) with four (4) 3/4" x 5-1/4" min. wedge anchors. Weld mounting plate to curb steel and back plate of PowerStop with a continuous 1/4" fillet weld. Anchor back plate of PowerStop to dock face with a minimum of four (4) 3/4" x 5-1/4" min. wedge anchors (Kit #2103-0003). See Figure 11.

Note: Trim or cut leveler front frame member as shown in Figure 12 when necessary to allow for pit floor mounting plate.

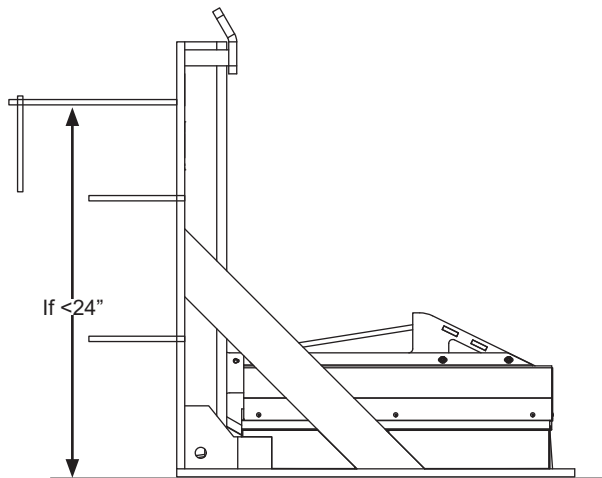

Figure 11

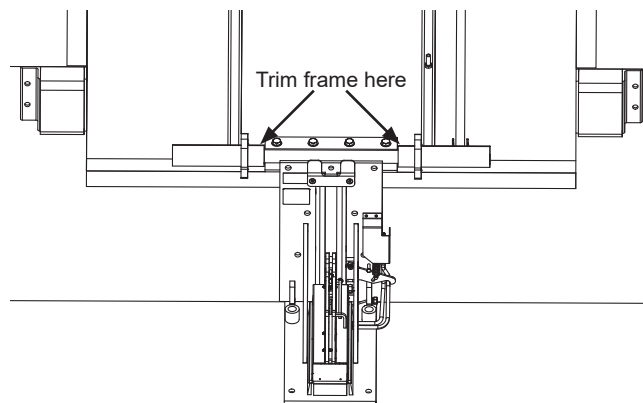

Figure 12

Driveway Mount (recommended when dock face is unsuitable for mounting)

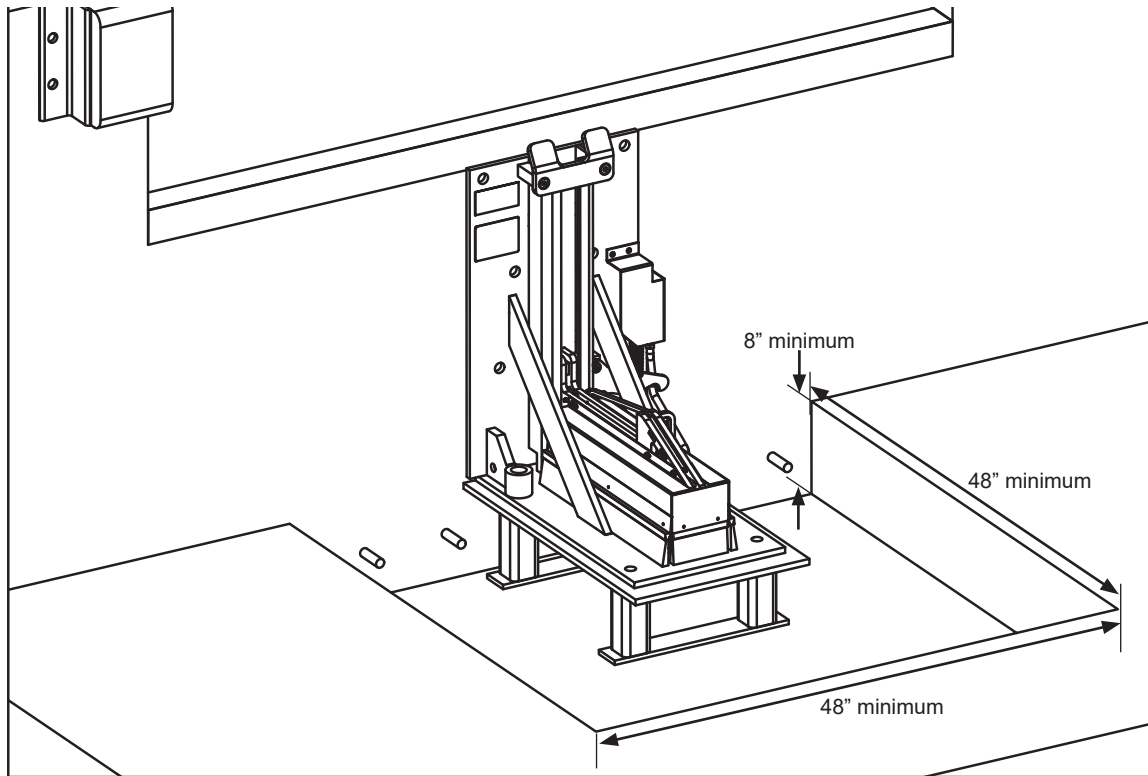

Figure 13

Note: Driveway mount requires attachment to a concrete drive greater than 8" thick. For asphalt drives, pour a 48" x 48" x 8" min. concrete pad and include six (6) 3/4" dowels into foundation wall as shown in Figure 13. Then proceed with adhesive anchors or weld plate embed.

- **Adhesive Anchors Method (Kit #9414-0058)**

At rear of PowerStop, drill 1-1/8" dia. x 7" deep holes and install two (2) 1" dia. adhesive anchors. At front of PowerStop, install two (2) 3/4" dia. x 5-1/4" min. wedge anchors. See Figure 14.

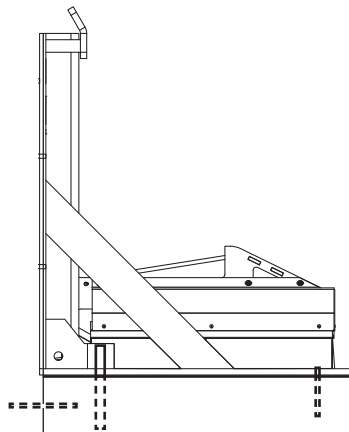

Figure 14

- **Drive Embed Method (Part #7953-0195, Figure 15)**

Weld-on:

Properly locate and level the drive embed weld plate in the drive approach. Observe cantilever conditions (page 14) for proper positioning. Weld restraint to embed plate with a continuous 1/4" fillet weld.

Bolt-on:

Properly locate and level the drive embed weld plate in the drive approach. Observe cantilever conditions (page 13) for proper positioning. Bolt the restraint to the embed plate using 1" dia. x 6" min. bolts at the rear, and 3/4" dia. x 6" min. bolts at the front.

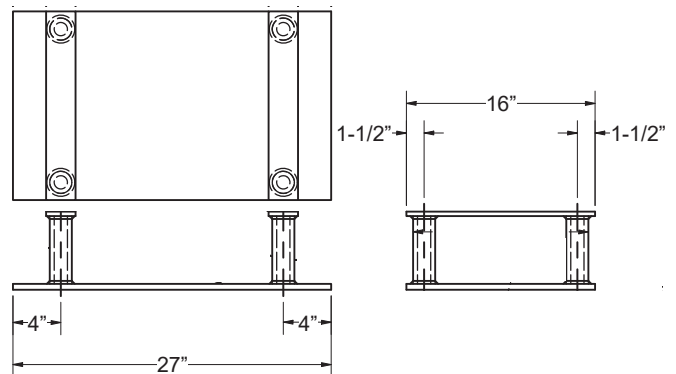

Figure 15

INSTALLATION

Cantilevered Dock (for bumper projection >4", cantilevered dock or Edge-Of-Dock leveler)

- **Driveway Mount**

Determine offset, then proceed with "Driveway Mount" instructions on page 13.

- **Wall Mount**

Refer to the cantilever bracket table on page 39 for available cantilever brackets and part numbers.

Anchor cantilever bracket to dock face with six (6) wedge anchors (3/4" x 5-14" min) or weld to the embed mounting plate with ten (10) 4" long, 1/4" fillet welds. Where possible, cantilever bracket should also be welded to curb angle with 1/4" fillet weld.

Note: Walls must be poured concrete, 8" thick minimum to install with wedge anchors. Concrete block or brick is not acceptable.

When cantilever bracket install is complete, weld three sides of PowerStop back plate to the cantilever bracket with ten (10) 4" long, 1/4" fillet welds.

Note: To determine size offset required, take total effective bumper projection (bumper size plus any cantilever) and subtract 4". See table and Figure 16 below.

Offset Formula			
Dim. A Bumper Projection	Dim. B Cantilever	-4"	= Offset Required
4"	+ Dim. B		
6"	+ Dim. B		
10"	+ Dim. B		
15"	+ Dim. B		

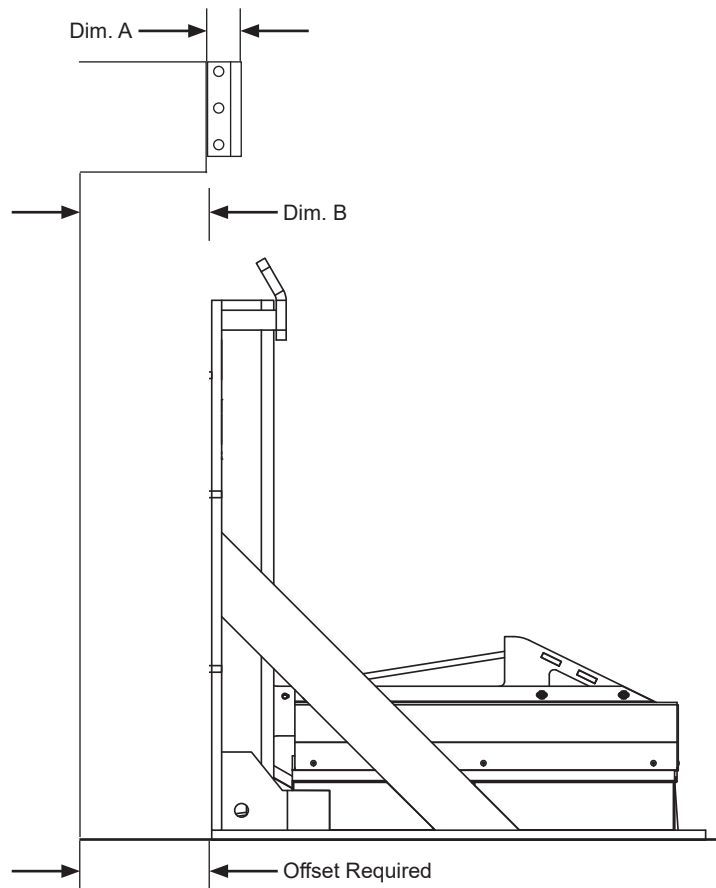

Figure 16

PowerStop Mechanical Operating Wand Bracket

- Mount PowerStop operating wand bracket (Figure 17) on the interior wall near the vehicle restraint (or as close to the control box as possible, if equipped). Mounting hardware supplied by others.
- Ensure bracket is not mounted upside-down or bracket will be unable to hold operating wand (Figure 18).

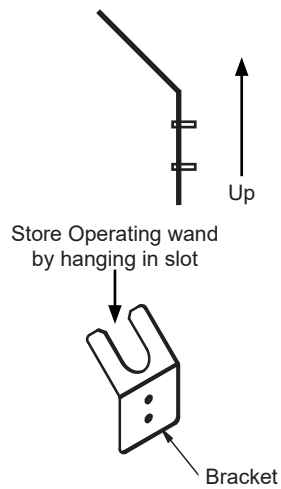

Figure 17

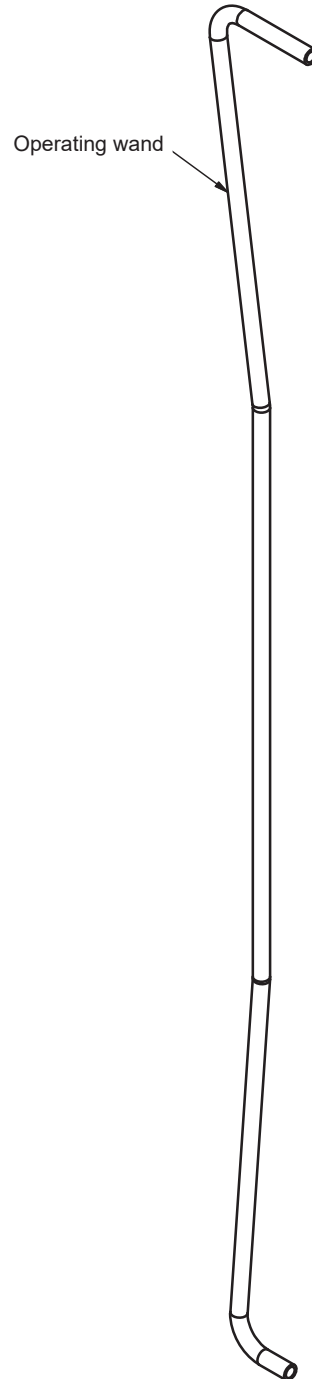

Figure 18

INSTALLATION

PowerStop Automatic Powerpack

Powerpack Location Options

- **Dock Face (A)**

Appropriate location when the likelihood of flooding, snow removal, and damage from transport vehicles is minimal.

- **Under Dock Leveler (B)**

When under dock location is used, ensure Powerpack is located where it will not interfere with the leveler in below-dock conditions. The routing of hydraulic and electrical lines from the Powerpack to the restraint are best placed through min. 3" PVC (hydraulic) and 3/4" conduit (electrical) chase during pit construction.

- **Inside Building (C)**

Locate Powerpack inside where there is minimal obstruction potential. The routing of hydraulic and electrical lines from the Powerpack to the restraint are best placed through min. 3" PVC (hydraulic) and 3/4" conduit (electrical) chase during pit construction.

See Figure 19 below for example of appropriate PVC and conduit chase for available mounting methods.

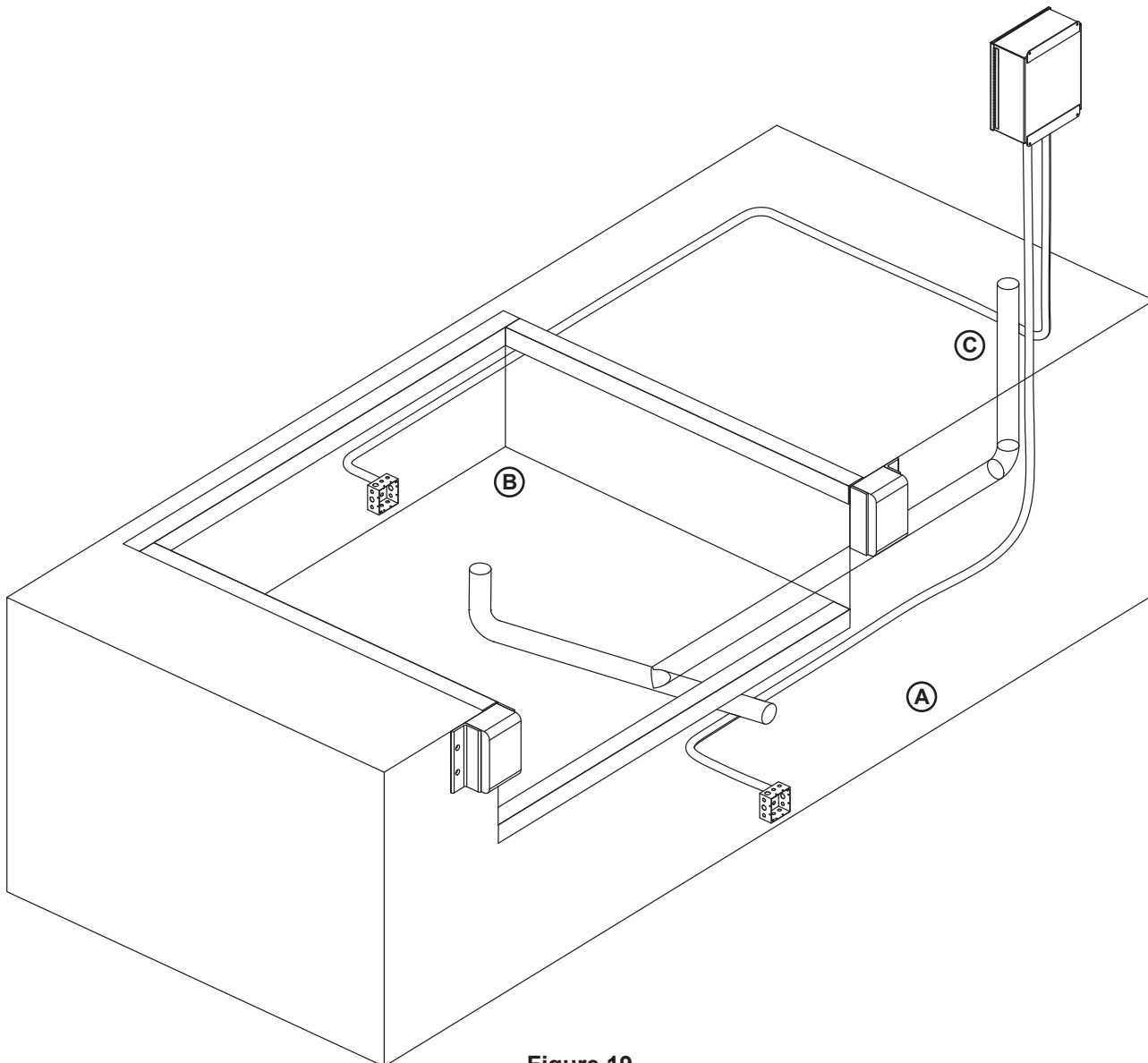

Figure 19

Powerpack Installation Overview

- Conduit, flexible or rigid, must be connected between the limit switch on the restraint and the Powerpack.
- Wiring to and from the restraint must be limited to restraint wires only.
- Do not run high voltage lines through the same conduit as restraint wires.
- Conduit and associated hardware to complete wiring and mounting of Powerpack are to be supplied by others.



Connect hydraulic hose to base end of release cylinder.



Connect hydraulic hose to rod end of release cylinder.

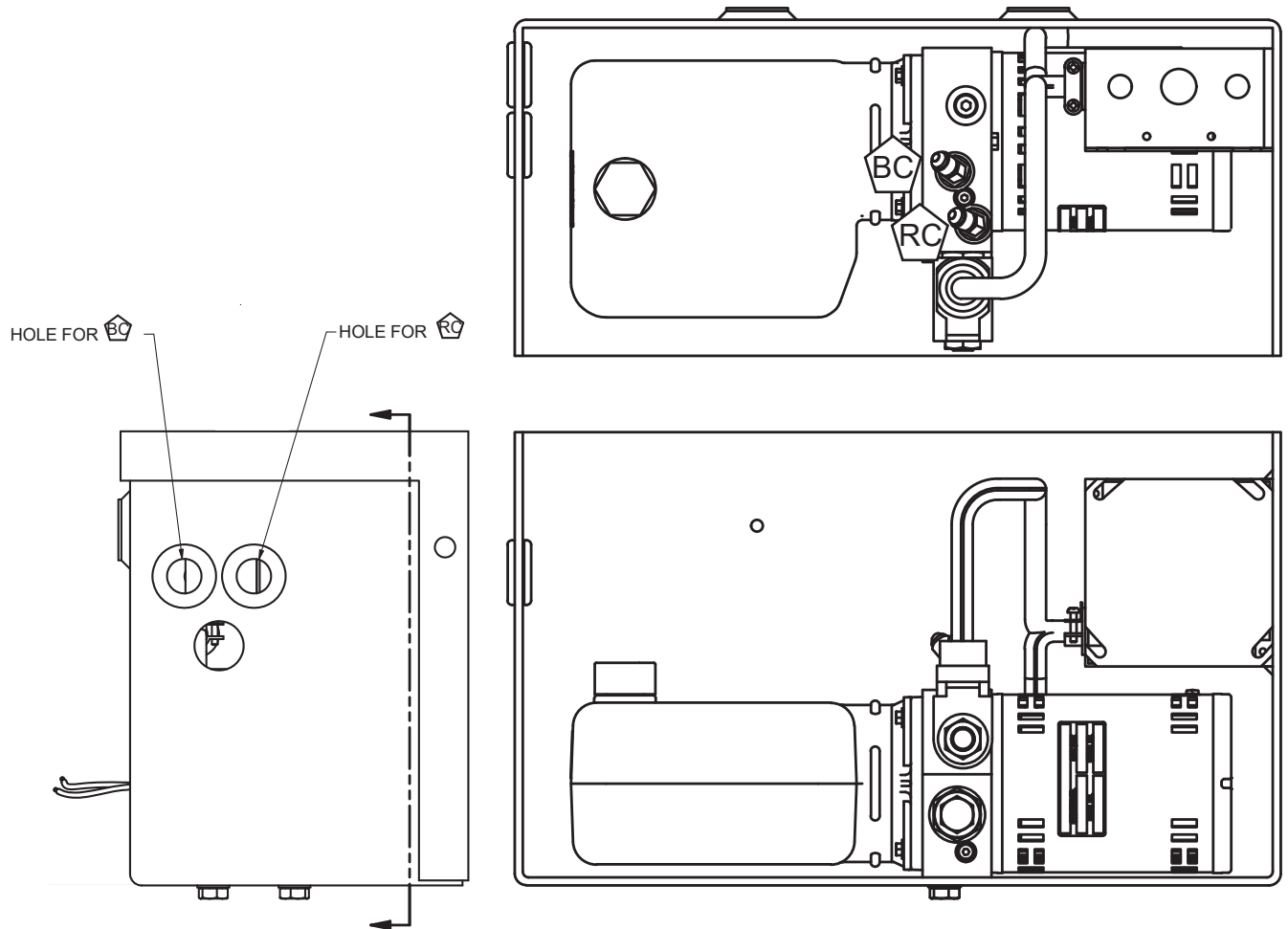

Figure 20

INSTALLATION

Install Control Panel and Wiring

! DANGER

Make sure that the power source has been locked out and tagged according to OSHA regulations and approved local electrical codes.

! WARNING

A hard hat or other applicable head protection should always be worn when working under or around a dock leveler.

Always stand clear of platform lip when working in front of the dock leveler.

! CAUTION

All electrical work — including the installation of the disconnect panel, control panel, and final connections to the pit junction box — must be performed by a certified electrician and conform to all local and applicable national codes.

NOTICE

DO NOT connect any dock equipment electrical wiring or ground connections until all welding has been completed.

DO NOT ground welding equipment to any electrical components of the dock equipment. Always ground welding equipment to the dock leveler frame, NEVER to the platform.

Failure to follow these instructions may damage the motor, wiring, and/or control panel.

NOTICE

Where indicated, all components must be connected to a SAFETY EARTH GROUND that conforms to the 1999 National Electrical Code Section 250-50 section (a) or section (c) for a grounding electrode system.

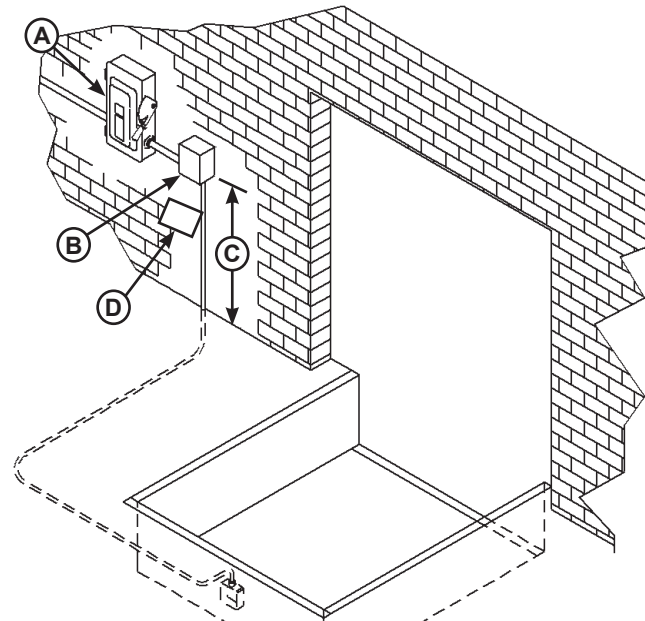

Figure 14

A— Disconnect Panel (provided by others) C— Distance, 48 in. (1219 mm)
B— Control Panel D— Placard

1. Mount the control panel (B) so bottom of control panel-to-dock floor distance is 48 in. (1219 mm, C).
2. Install electrical disconnect panel (A) if not already installed (provided by others). It is recommended to locate disconnect panel adjacent to control panel (B).
3. Install and connect the control wiring as shown in installation drawings.
4. Connect the control wiring to the field wires in the dock equipment junction boxes. Refer to the electrical diagrams supplied with the dock equipment.

Note: When installing electrical controls in a temperature-controlled environment, the installer must determine an appropriate means to isolate/prevent thermal and vapor transfer through electrical conduit where conduit routing crosses temperature zones. Systems, LLC is not responsible for any damage due to moisture collecting inside the control panel caused by improper isolation/prevention of thermal and vapor transfer through the conduit. Refer to Tech Service Bulletin 19-053 for more information.

5. Install placard (D). Make sure placard is in plain view of dock leveler and/or vehicle restraint operations. Suggested placement of placard is near control box attached to electrical conduit by using nylon cable tie. See page 21.

Install Outside Light Assembly and Signs

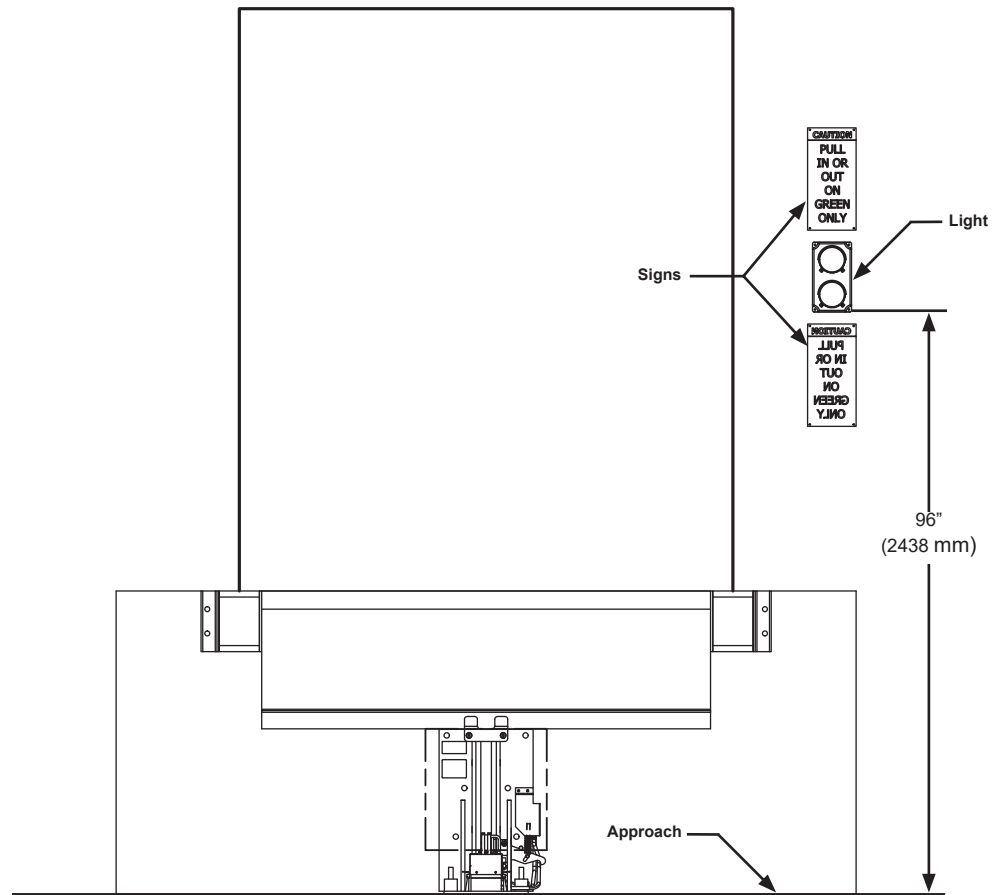

Figure 22

Note: Installation measurements shown are recommended based on typical dock conditions. Some installations may require alternate placement.

1. Mount the Outside Light Assembly so bottom of outside light-to-drive distance is 96 in. (2438 mm).
2. Connect the wiring for the Outside Light Assembly.
3. Install “CAUTION: PULL IN OR OUT ON GREEN ONLY” signs on outside of building above and below Outside Light Assembly.
4. Install “CAUTION: ENTER ON GREEN ONLY” sign inside building near control box.
5. Install Placard (see page 20).

NOTICE

The iDock Control System is designed to function with 12v DC outside lights only.

Using 115v AC or other non-12v DC outside lights and wiring will cause the iDock Control System to enter a fault state and equipment will not function.

If 12v DC outside lights are already present and functioning, they can be re-used, but new wiring should always be run to ensure correct operation.

INSTALLATION

Placard Installation Instructions

- Owner/Users are responsible for the installation and placement of product placards.
- Make sure placard is in plain view of dock leveler and/or vehicle restraint operations.
- Suggested placement of placard is near control box attached to electrical conduit by using nylon cable tie. If there is no control box present, mount placard on wall to the immediate left of leveler at eye level.

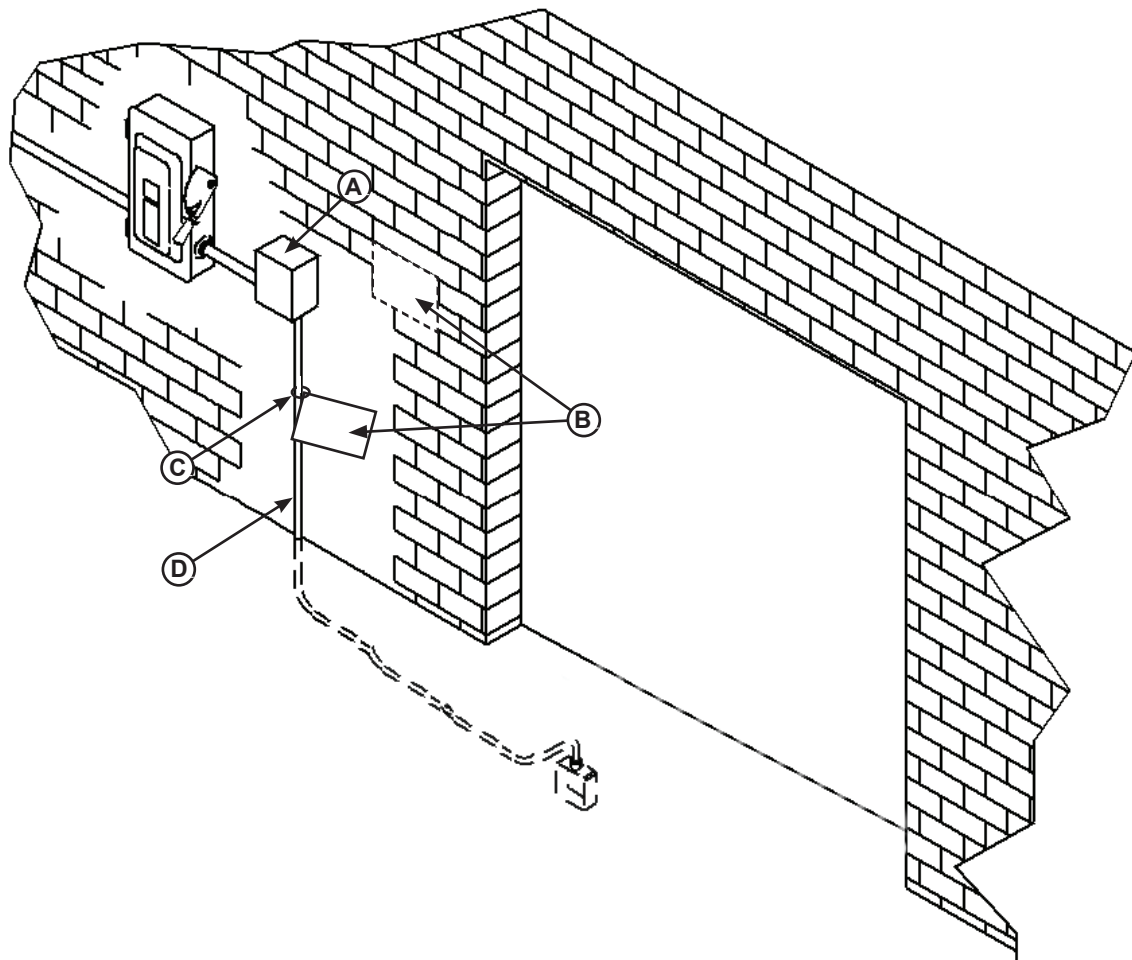

A - Control Box

B - Placard

C - Nylon Cable Tie

D - Conduit

Figure 23

Put New Restraint Into Service



WARNING

A hard hat or other applicable head protection should always be worn when working under or around a dock leveler.

Always stand clear of platform lip when working in front of the dock leveler.

1. Once all installation work is completed, disconnect the external lifting device and lifting brackets.
2. Remove latch shipping bolt from latch mechanism. Latch shipping bolt prevents PowerStop from raising during shipment and can be safely removed after install.

OPERATION

Operational Precautions

DANGER

Stay clear of dock leveler and vehicle restraint when transport vehicle is entering or leaving dock area.

DO NOT move or use the dock leveler or restraint if anyone is under or in front of leveler.

Keep hands and feet clear of pinch points. Avoid putting any part of your body near moving parts.

WARNING

Only trained personnel should operate the dock leveler and vehicle restraint.

DO NOT use a broken or damaged dock leveler or vehicle. Make sure proper service and maintenance procedures have been performed on the equipment before using.

Transport vehicle wheels must be chocked unless the vehicle restraint is used. Never remove the wheel chocks until loading/unloading is finished and transport vehicle driver has been given permission to leave.

Make sure platform lip rests on the transport vehicle bed with at least 4 in. (102 mm) of overlap.

Maintain a safe distance from side edges of leveler during the loading/unloading process.

WARNING

Once the vehicle restraint has been activated, the dock attendant must visually inspect to assure that the restraint hook has properly engaged the Rear Impact Guard (RIG) bar.

Proper engagement occurs when the hook is able to travel vertically, contacting the bottom edge of the horizontal member of the RIG, without obstruction.

Operation - Stop-M, Stop-MML

1. Check that the transport vehicle is positioned squarely against the dock bumpers.
2. Raise the restraint hook fully by pulling latch release with the handle provided.
3. Restraint will ENGAGE on transport vehicle RIG. Visually inspect restraint for proper engagement.

Note: If restraint cannot properly restrain the vehicle due to a missing or damaged RIG bar, advise driver of the transport vehicle and dock personnel. The transport vehicle must be secured by other means.

4. Position dock leveler onto transport vehicle.
5. When loading or unloading is complete, return dock leveler to the stored position.
6. Lower the restraint fully by pressing down on the hook weldment with the handle provided. The restraint hook should lower fully until the latch is engaged.

Operation - Stop-MAL

1. Check that the transport vehicle is positioned squarely against both dock bumpers.
 - Inside light - RED
 - Outside light - GREEN
2. Raise the restraint hook fully by pulling latch release with the handle provided.
3. Restraint will ENGAGE on transport vehicle RIG. Visually inspect restraint for proper engagement.
 - Inside light - GREEN
 - Outside light - RED
4. Position dock leveler onto transport vehicle.
5. When loading or unloading is complete, return dock leveler to the stored position.
6. Lower the restraint fully by pressing down on the hook weldment with the handle provided. The restraint hook should lower fully until the latch is engaged.
7. Transport vehicle can now depart.
 - Inside light - RED
 - Outside light - GREEN

Operation - Stop-AAL

1. Check that the transport vehicle is positioned squarely against both dock bumpers.
 - Inside light - RED
 - Outside light - GREEN
2. Push ENGAGE button to activate restraint.
 - Inside lights - AMBER
 - Outside light - RED
3. Restraint will ENGAGE on transport vehicle RIG.
 - Inside light - GREEN
 - Outside light - RED
4. Visually inspect restraint for proper engagement.
5. Position dock leveler onto transport vehicle.
6. When loading or unloading is complete, return dock leveler to the stored position.
7. Push RELEASE button to store restraint.
 - Inside lights - AMBER
 - Outside light - RED
8. Transport vehicle can now depart.
 - Inside light - RED
 - Outside light - GREEN

Operation - Auto Re-Engage (Stop-AAL only)

Note: Auto Re-Engage requires an iDock Control System. Units without an iDock Control System do not have this functionality.

After restraint has been engaged with successful capture of RIG bar, these restraints will automatically attempt to re-engage if they leave the working zone:

- When restraint hook is lowered to the stored position without pressing the RELEASE button, the controls will automatically attempt to re-engage the hook one (1) time.
 - If hook successfully captures the RIG bar again, the light communication will remain the same.
 - If hook is unable to return to the working zone after one (1) attempt, the hook will automatically return to the stored position, and the iDock Control System will alert the operator that the restraint is no longer engaged with a Bypass Mode prompt. See "Operation - Unsuccessful Engage."

Operation - Bypass (Stop-MAL and AAL)

If the trailer RIG (Rear Impact Guard) is damaged or missing, dock leveler can be used in BYPASS.

1. Secure transport vehicle wheels by other means.
2. Activate BYPASS mode through menu screens under OPERATION MODE.
 - Inside light - GREEN & AMBER
 - Outside light - RED
3. Position dock leveler onto transport vehicle trailer.
4. When loading or unloading is complete, return dock leveler to the stored position.
5. Reset BYPASS mode to NORMAL mode by pressing the RELEASE button once, or through menu screens under OPERATION MODE.
 - Inside light - RED
 - Outside light - GREEN
6. Release the transport vehicle wheels when transport vehicle is ready to depart.

Operation - Bypass From Unsuccessful Engage (Stop-AAL only)

If the restraint fails to successfully ENGAGE a trailer RIG, the hook will automatically return to the stored position.

- Inside light - AMBER & RED
- Outside light - RED

Bypass mode can then be activated by pressing ENTER button (user code may be required).

- Inside light - GREEN & AMBER
- Outside light - RED

Or, to reset back to NORMAL mode, press RELEASE button.

- Inside light - GREEN
- Outside light - RED

See the iDock Owner's/User's Manual for more information on iDock menus and navigation.

OPERATION

Multi-Colored & Outside Light Sequence Charts

Normal Operation

Condition	Lights	
	Inside	Outside
Ready For Use	Red	Green
Leveler Operating or Restraint Engaging/Releasing In Progress	Amber	Red
Restraint Engaged	Green	Red
Restraint Engage Failure	Red/Amber, Display Backlight*	Red
Emergency Stop Active	Red (solid)*	Red (solid)

*If equipped, Audible Alarm will also be active.

Bypass Mode

Condition	Lights	
	Inside	Outside
Restraint Engage Failure (Bypass Mode prompt)	Red/Amber, Display Backlight	Red
Bypass Mode	Green/Amber (Green/Red on Dock Alert)	Red
Reset Attempted (Leveler in Use)	Red/Amber, Display Backlight	Red
Reset Attempted (Door Open)	Green/Amber, Display Backlight	Red
Reset Lights to Normal Mode	Red, Display Backlight (5 seconds)	Green

Menu & Diagnostics

Condition	Lights	
	Inside	Outside
Main Menu Active	Red (solid)	Red (solid)
System Fault Present	Red/Amber	Red
Restraint Use Disabled	Amber	None

Maintenance Precautions

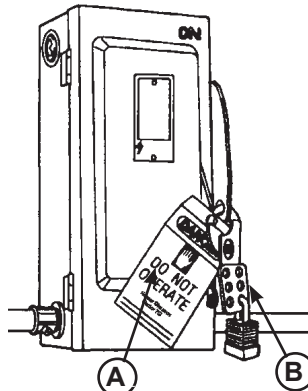

Figure 24

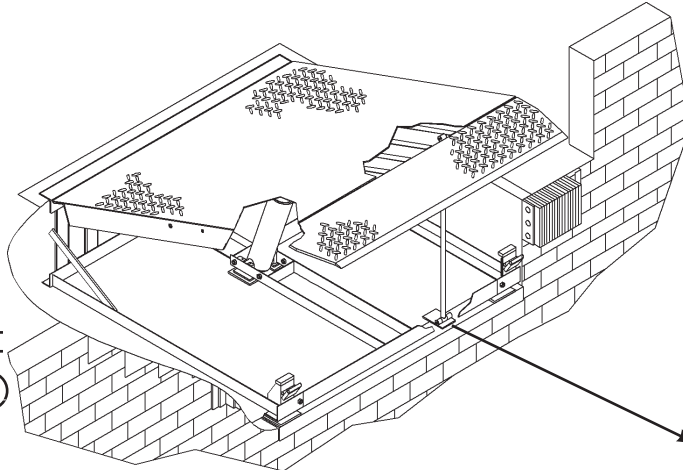

Figure 25

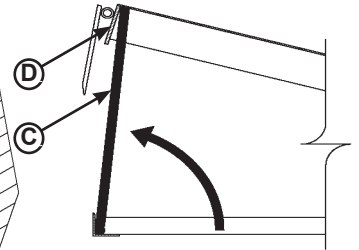
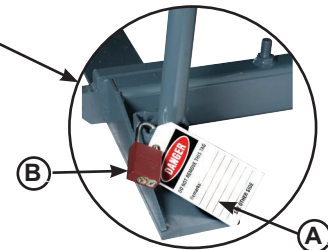

Figure 26



A— Tag Out Device B—Lock Out Device C— Maintenance Prop D— Header

! DANGER

Unless the dock leveler is equipped with a tethered remote, two people are required to engage the maintenance prop: one person to operate the unit, the other person to engage the maintenance prop.

In addition, it is recommended and good safety practice to use an additional means to support the dock platform and lip anytime when physically working in front of or under the dock leveler. This additional means may include, but is not limited to a boom truck, fork truck, stabilizing bar or equivalent.

When working with electrical or electronic controls, make sure that the power source has been tagged (A) and locked out (B) according to OSHA regulations and approved local electrical codes (see Figure 24).

Whenever maintenance is to be performed under the dock leveler platform, support the platform with maintenance prop (C). Position the maintenance prop behind front header plate (D) while staying clear of the lip. The lip will fold down after the platform has rested on the maintenance prop. Lock the maintenance prop in the service (upright) position using an OSHA approved lockout device* (B) and tag out device* (A). See Figures 25 and 26.

! WARNING

Always post safety warnings and barricade the work area at dock level and ground level to prevent unauthorized use of the unit before maintenance is complete.

Only the person servicing the equipment should have the capability to remove the lockout devices. The tag out devices* must inform that repairs are in process and clearly state who is responsible for the lockout condition.

! WARNING

A hard hat or other applicable head protection should always be worn when working under or around a dock leveler.

Always stand clear of platform lip when working in front of the dock leveler.

* Refer to OSHA regulations 1910.146. Confined Space and 1910.147. Lockout/Tagout

MAINTENANCE

Periodic Maintenance

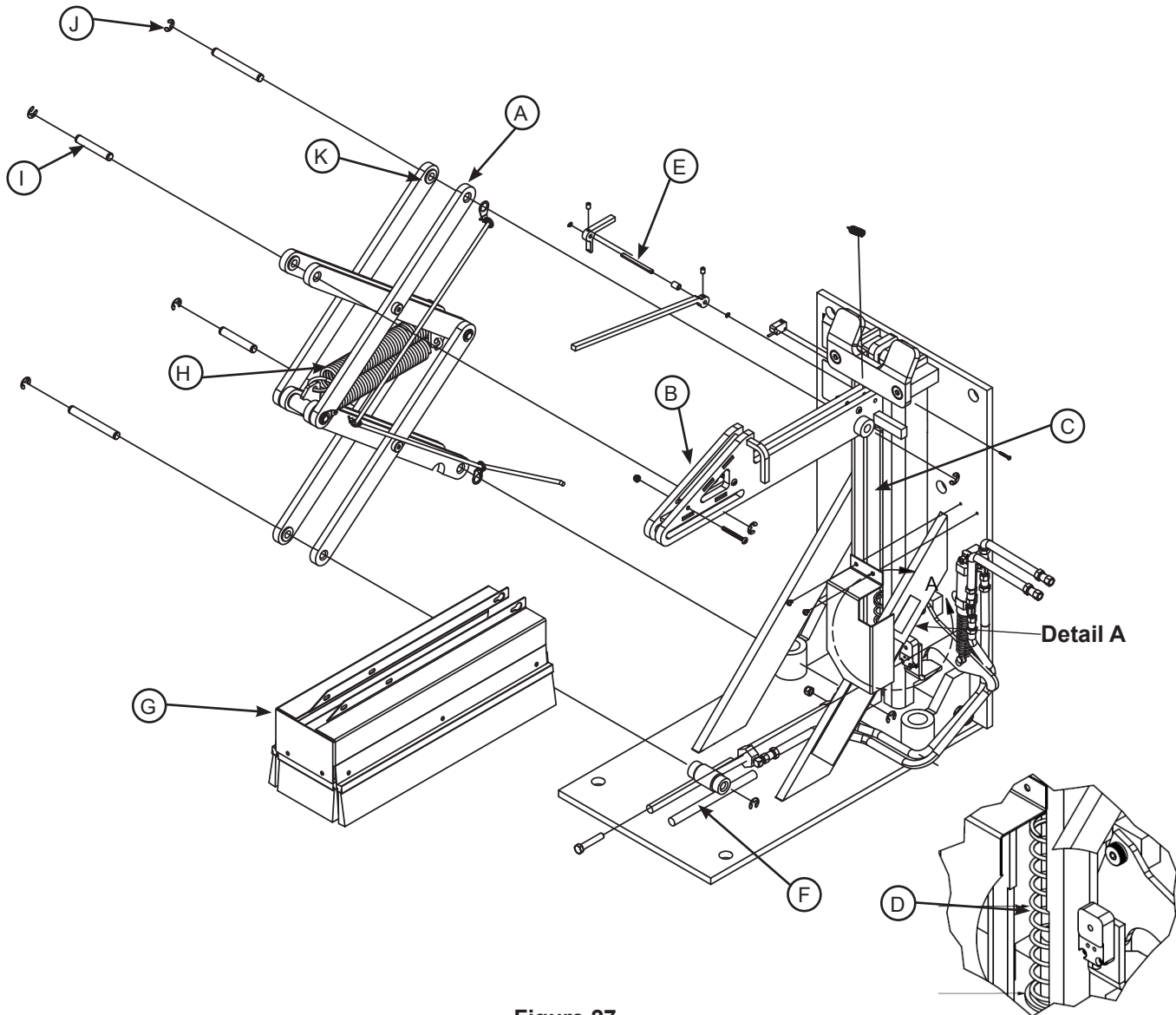

Figure 27

A - Scissors Assembly
B - Hook Weldment
C - Rear Vertical Track

D - Spring, Compression
E - RIG Sensor Bar
F - Bottom Slide Track

G - Debris Guard
H - Main Springs
I - Pin

J - E-Clip
K - Bearing

Detail A

Daily Maintenance

- Clear any debris in or around unit to prevent operation issues.
- Make sure that all the inside and outside signal lights work (if equipped).

Weekly Maintenance

- Operate the vehicle restraint through the complete operating cycle to maintain lubrication of moving parts.
- Inspect the rear vertical track area (C). The track area must be kept free of dirt and debris.

Periodic Maintenance

Quarterly Maintenance

- Complete daily and weekly maintenance.
- Clean and lubricate scissors assembly (**A**) and all pivot points (**K**) with low temp. white lithium aerosol grease.
- Make sure rear track assist spring (**D**) is properly seated at the bottom of the rear track.
- Check bumpers for more than 1" of wear. Replace worn, loose, damaged or missing bumpers.
- **Automatic units only:**
Check reservoir fluid level (**O**).

See Figures 27 and 28 for reference.

NOTICE

Failure to clean and properly lubricate the vehicle restraint will cause abnormal operation.

Yearly Maintenance

- Complete Quarterly Maintenance.
- **Automatic units only:**
Change hydraulic fluid (varying environmental conditions may require this more frequently). See below for list of approved fluids.

Approved Hydraulic Fluids (Automatic units)

To ensure normal operation of the dock leveler and vehicle restraint, use only aircraft hydraulic fluid designed to meet or exceed military specification MIL-H-5606-G. It is recommended that the following hydraulic fluids be used:

- ULTRA-VIS-HVI-15
- Aero Shell Fluid 4 or Fluid 41
- Mobile Aero HFA Mil-H5606A or Aero HF
- Texaco Aircraft Hydraulic Oil 15 or 5606
- Exxon Univis J13
- Castrol Brayco Micronic 756

These fluid brands can be mixed together. Use of hydraulic fluids with equivalent specifications to those listed here are acceptable.

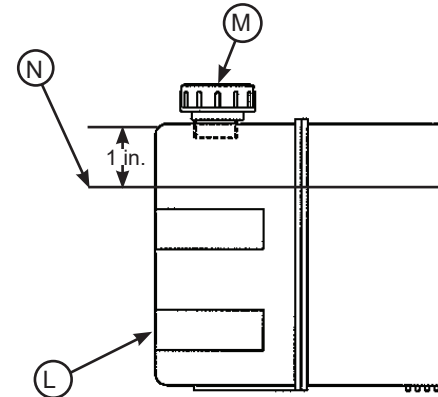

Figure 28

L - Reservoir
M - Breather Cap
N - Fluid Level

Checking Reservoir Fluid Level (Automatic units)

1. Put the vehicle restraint in the stored position.
2. Turn OFF all electrical power to the vehicle restraint.*
3. Remove Powerpack cover and wipe off reservoir (**L**) as needed.
4. Measure fluid level (**N**). The fluid level should be approximately 1 in. (25 mm) from top of reservoir (**L**) with vehicle restraint stored. See Figure.
5. Add hydraulic fluid if necessary. Use only recommended fluid (see Approved Hydraulic Fluids).
6. Reinstall Powerpack cover.
7. Turn ON electrical power.

See Figure 28 for reference.

NOTICE

A low fluid level, or the use of hydraulic fluids not equivalent to the fluid types recommended, will cause abnormal operation of the vehicle restraint and voiding of warranty.

ADJUSTMENTS

Adjust Dock Leveler and Vehicle Restraint Interlock

DANGER

It is recommended and good safety practice to use an additional means to support the dock platform and lip anytime when physically working in front of or under the dock leveler. This additional means may include, but is not limited to a boom truck, fork truck, stabilizing bar or equivalent.

WARNING

Always post safety warnings and barricade the work area at dock level and ground level to prevent unauthorized use of the dock leveler before maintenance is complete.

A hard hat or other applicable head protection should always be worn when working under or around a dock leveler.

Always stand clear of platform lip when working in front of the dock leveler.

Dock Leveler & Vehicle Restraint Interlock Options

There are two options to interlock the dock leveler and vehicle restraint*:

- **Restraint Engage before Leveler Operate (RELO) Interlock:** Dock leveler can be interlocked with a vehicle restraint to prevent the leveler from operating until the restraint has engaged the transport RIG (Rear Impact Guard) when the OPERATION MODE is NORMAL and has NOT been switched to BYPASS MODE.
- **Leveler Stored before Restraint Release (LSRR) Interlock:** Vehicle restraint is interlocked with the dock leveler so that the restraint cannot be operated until the leveler is stored in the cross traffic position (lip fully folded, inside the keepers, and the platform level with the dock floor).

Interlocking is overridden when the OPERATION MODE is in BYPASS. This allows the independent operation of the leveler (the restraint cannot be operated in BYPASS MODE).

Pressing the restraint RELEASE button when in BYPASS mode will return the leveler to NORMAL operating mode.

Special interlocking options are available upon request. Call Systems, LLC to discuss interlock options to meet your specific needs.

*Dock levelers equipped with Auto-Return-To-Dock have limited interlocking options. Auto-Return-To-Dock feature is not available for dock levelers equipped with combination dock leveler/vehicle restraint control panels.

Adjust Dock Leveler and Vehicle Restraint Interlock

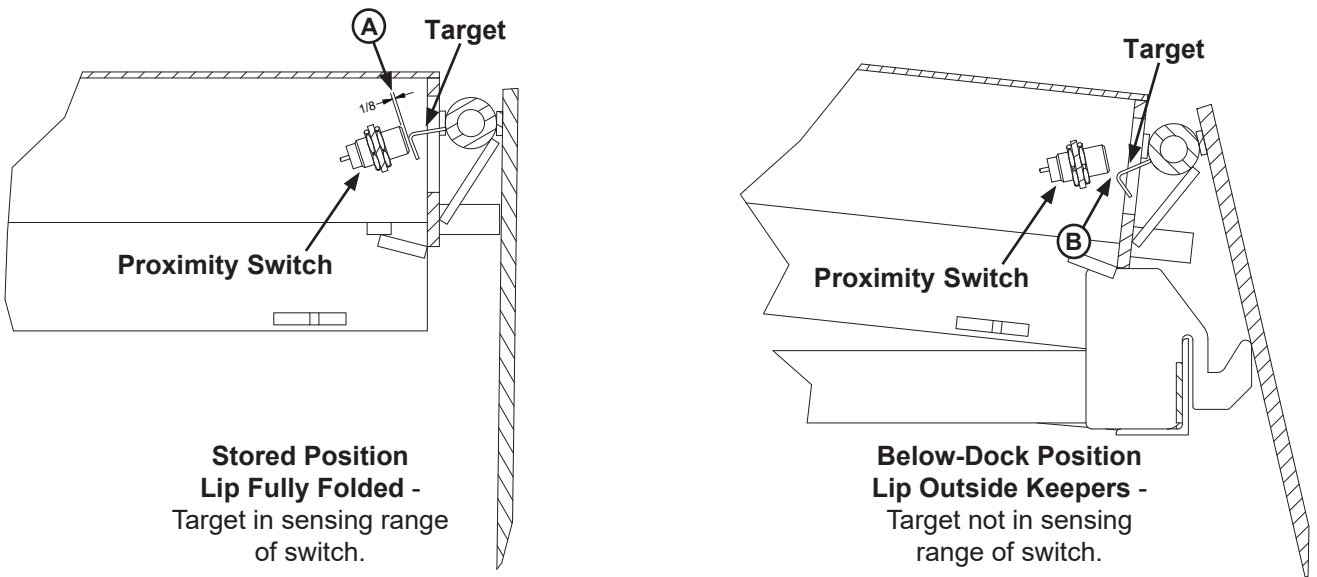

Figure 29

1. The dock leveler should be in the cross traffic position before beginning tests.
 2. Back a transport vehicle with RIG bar into dock. A test fixture may be used to simulate the RIG bar. Use care to avoid damage to the equipment or harm to the operator.
 3. Press the RAISE button. The dock leveler should NOT raise. If the leveler did not raise, proceed with step 4. If the leveler did raise, decrease dimension (A), so that the target is in the sensing range of the switch. Typical factory setting for (A) is approximately 1/8". Make adjustments at switch until leveler does not raise when the vehicle restraint is not engaged on transport vehicle RIG bar. See Figure 29.
 4. Momentarily press the ENGAGE button. The vehicle restraint automatic engage cycle will be activated and the restraint will engage the transport vehicle RIG bar.
 5. Raise the dock by pressing the RAISE button until the lip is fully extended. Release the RAISE button. The leveler will drop to the floor of the transport vehicle. If a RIG test fixture is used it should allow the leveler to drop to the full below dock position without the contact between the lip and test fixture.
 6. Press the RELEASE button. The vehicle restraint should NOT disengage from the transport vehicle RIG bar or test fixture. If the vehicle restraint did NOT disengage, proceed with Step 7. If the vehicle restraint DID disengage, move the switch farther from the target or bend the target to increase dimension (B) so that the target is not in the sensing range of the switch. Make adjustments at switch and/or target until vehicle restraint does not disengage transport vehicle. See Figure 29.
- Note:** If adjustments are required in this step, make sure that the interlocking described in Step 3 is still in effect after Step 6 adjustments are complete.
7. Press the RAISE button. The dock leveler will raise. The leveler lip will fold as the platform raises. When the lip is fully folded, release the RAISE push button. The leveler will descend to the cross traffic position.
 8. Momentarily press the RELEASE button. The vehicle restraint will return to the stored position.

NOTICE

Work lip by hand when making adjustments to make sure that target does NOT contact switch as lip extends.

TROUBLESHOOTING

DANGER

Unless the dock leveler is equipped with a tethered remote, two people are required to engage the maintenance prop: one person to operate the unit, the other person to engage the maintenance prop.

In addition, it is recommended and good safety practice to use an additional means to support the dock platform and lip anytime when physically working in front of or under the dock leveler. This additional means may include, but is not limited to a boom truck, fork truck, stabilizing bar or equivalent.

WARNING

When service under the dock leveler is required, always lock all electrical disconnects in the OFF position after raising the platform and engaging the maintenance prop.

Always post safety warnings and barricade the work area at dock level and ground level to prevent unauthorized use of the dock leveler before maintenance is complete.

A hard hat or other applicable head protection should always be worn when working under or around a dock leveler.

Always stand clear of platform lip when working in front of the dock leveler.

All Units

Symptom	Possible Cause	Solution
Restraint will not raise or lower.	Debris/damage.	Remove debris guard; check for debris jammed in or damage to scissor mechanism. Inspect track for debris.
	Improper lubrication.	Lubricate latch release leveler. Lubricate pivot points on scissor mechanism.
	Damaged parts.	Damaged or missing compression spring. Damaged or missing scissor mechanism springs. Worn out or damaged flanged bearings in scissor mechanism. Damaged scissor mechanism.

TROUBLESHOOTING

Automatic Units

Before performing the detailed troubleshooting procedures, check the following items first:

- Check all fuses inside the control panel(s). Replace any blown fuse(s) with a fuse of equal specification.
- Make sure the correct voltages are present at the proper locations inside the control panel(s).

Symptom	Possible Cause	Solution
Restraint will not raise.	If lights are on but motor does not run: motor overload device tripped or fuse blown.	Reset overload or replace fuse. Note: When replacing fuses or breakers, the replacement must have the same specification as the original.
	Faulty wire connections.	Check all wire connections for damage and/or corrosion.
	Faulty stored prox switch.	Check stored prox switch wiring and operation. Note: Stored prox switch has two lights on switch: GREEN when metal is present, on RED when no metal is present. Replace if lights do not work
	Faulty RIG sensor.	RIG sensor failed or wired incorrectly.
Motor energizes, but does not run.	Faulty motor.	Replace motor.
	Capacitor wired incorrectly or faulty.	Check wiring to capacitor.
	Insufficient voltage.	Check wire size to control box from facility. Consult Tech Services for correct wire size.
Motor energizes and runs, but restraint will not raise or lower.	Low hydraulic fluid.	Check for leaking cylinders or hoses. Fill hydraulic fluid to correct level (see page 19).
	Clogged suction filter.	Check for water contamination. Drain and remove fluid reservoir to clean suction filter.
	Faulty coil or wiring.	Check coil wiring. Coil should be energized for restraint to raise and de-energized to lower.
	Faulty spool valve.	Check valve for damage or contamination/clogged passages.

TROUBLESHOOTING

Automatic Units (continued)

Symptom	Possible Cause	Solution
Motor energizes and runs, but restraint will not lower	Faulty coil, relay or wiring.	Check coil wiring and relay operation. Coil should be de-energized to lower restraint.
	Faulty spool valve.	Check valve for damage or contamination/clogged passages.
	RIG wedge.	Back up the transport vehicle and press RELEASE again.
Restraint moves in one direction only.	Faulty spool valve.	Check valve for damage or contamination/clogged passages.
	Faulty coil or wiring.	Check coil wiring. Coil should be energized for restraint to raise and de-energized to lower.
Lights don't change.	Faulty stored prox switch.	Check stored prox switch wiring and operation. Note: Stored prox switch has two lights on switch: GREEN when metal is present, on RED when no metal is present. Replace if lights do not work
Lights not flashing, or not on.	Faulty flasher relay.	Check flasher relay operation. Note: Flasher can fail closed (lights on steady, not flashing) or fail open (lights will not be on).
	Faulty light bulbs.	Check light bulb operation.
Alarm on or caution light on.	Faulty RIG sensor.	RIG sensor failed or wired incorrectly.

If additional troubleshooting assistance is required, contact Systems, LLC Technical Services with equipment serial number or customer order number (CO#).

Technical Service at 800-643-5424 or techservices@loadingdocksystems.com

RIG Sensor Assembly

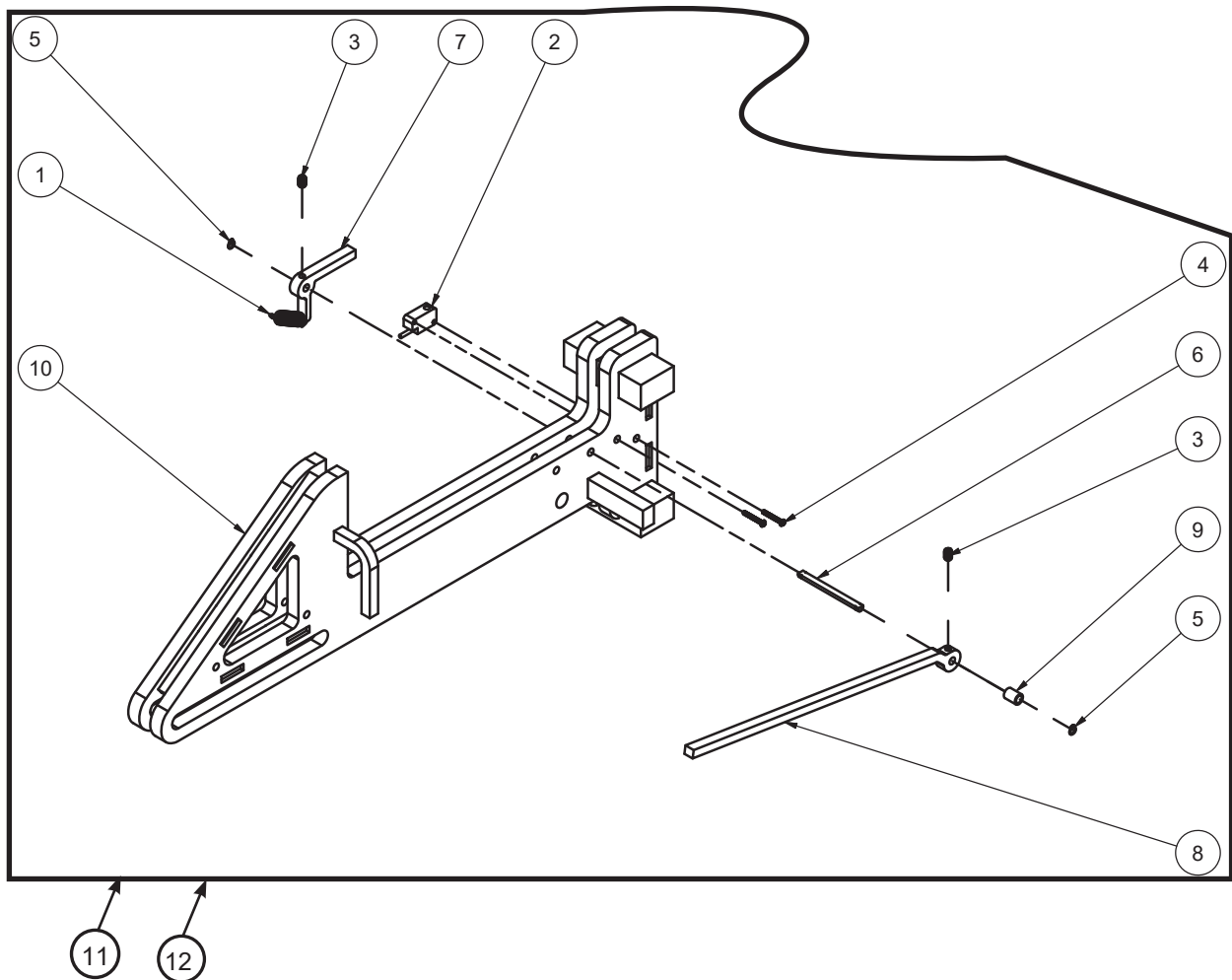

Item	Quantity	Part Number	Description
1	1	0941-0021	Spring, Extension, SS
2	1	0961-0614	Prox Switch, RIG Sensor
3	2	2101-0032	Screw, 1/4-20 x 0.38, Black Oxide
4	2	2101-0376	Screw, RHMS, Torx, 4-40 UNC x 0.875
5	2	2101-0349	Retaining Ring, External, Zinc Plated
6	1	9411-0103	Pin, RIG Sensor Bar
7	1	9411-0104	Connection, RIG Sensor Bar
8	1	9411-0105	RIG Sensor Bar
9	1	9411-0107	Spacer, RIG Sensor Bar
10	1	9413-0123	Hook Weldment, Tall Profile (Standard)
		9413-0127	Hook Weldment, Low Profile (Optional, not shown)
11	1	9416-0004	Kit, Stop18, Rig Sensor Assembly (Tall Profile) Items 1-10
12	1	9416-0005	Kit, Stop18, Rig Sensor Assembly (Low Profile, not shown) Items 1-10

PARTS

PowerStop M (Mechanical) Parts Breakdown

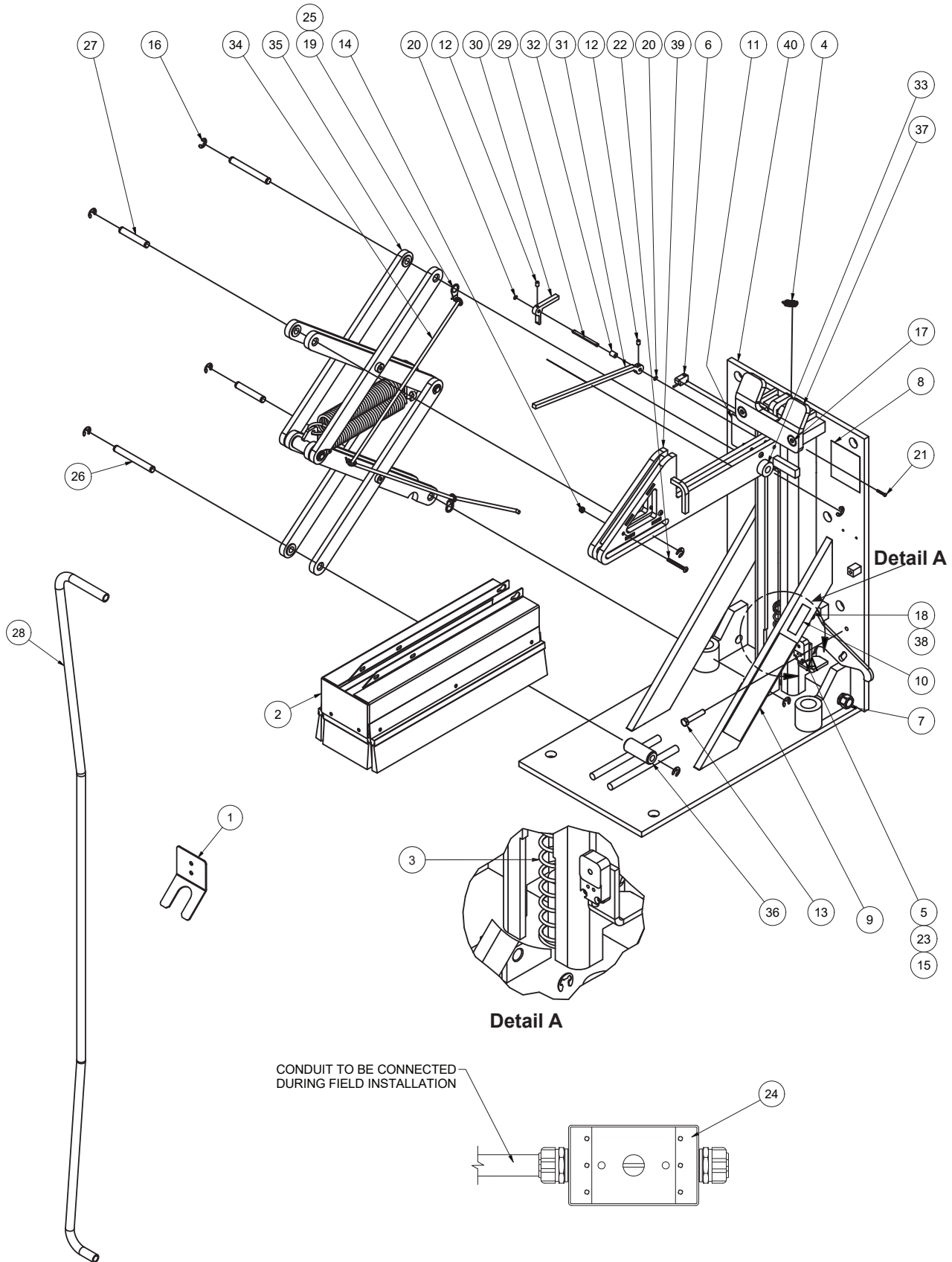

PARTS

Item	Quantity	Part Number	Description
1	1	0192-0161	Bracket, Stop M, Release Bar
2	1	0195-0052	Stop, Debris Guard Assembly
3	1	0941-0018	Spring, Compression, 1.937" DIA X 7.402"LG,. 138 Wire
4	1	0941-0021	Spring, Extension, SS, 0.45" DIA X 1.76" LG 0.059 Wire DIA
5	1	0961-0538	Prox SW, Flat, NO, 20-250VAC
6	1	0961-0614	Prox Switch, RIG Sensor
7	1	1431-0239	Connector, Tubing, 1/2", Metal
8	1	1751-0135	Decal - Warning
9	1	1751-0444	Decal - Poweramp/PowerStop
10	1	1751-0735	Decal, Made In The USA
11	1	1751-1290	Decal, Serial Number
12	2	2101-0032	Screw, SHSS, 1/4"-20 UNC X 3/8"
13	1	2101-0089	Screw, HHCS, 3/8"-16 x 2.00", Grade 2, Zinc Plated
14	3	2101-0151	Nylon Lock Nut, 10-24 UNC
15	2	2101-0156	Washer, Lock #8, Regular Split.
16	8	2101-0189	E-Ring, 1/2"
17	2	2101-0228	Screw, FSHCS, 1/2"-13 UNC x 1.00"
18	1	2101-0335	Screw, Shoulder, 1/2" x 3/8", Zinc Plated
19	2	2101-0336	Washer, Tag Hole, 1/2", Stainless Steel
20	2	2101-0349	Retaining Ring, External, Zinc Plated
21	2	2101-0376	Screw, RHMS, Torx, #4-40 x 7/8"
22	3	2101-0377	Screw, THMS, Torx, #10-24 x 2.00"
23	2	3051-0388	Screw, PHMS, #6-32 UNC x 5/8"
24	1	2753-0004	J-Box Assembly, 2-Lead, 26.5", (Not required on units with manual lights.)
25	3	3051-0001	Cable Tie
26	2	9202-0042	Pivot Pin, Long, 0.499" DIA X 4.25" LG
27	2	9202-0043	Pivot Pin, Short, 0.499" DIA X 3.00" LG
28	1	9411-0091	Release Lever Wand
29	1	9411-0103	Pin, RIG Sensor Bar
30	1	9411-0104	Connection, RIG Sensor Bar
31	1	9411-0105	RIG Sensor Bar
32	1	9411-0107	Spacer, RIG Sensor Bar
33	2	9412-0161	Tube, 1-1/4" OD x 9/16" ID x 0.594"
34	1	9412-0289	Conduit, 1/4", Split Flex, 35" LG
35	1	9413-0062	Scissor Lift Assembly
36	1	9413-0068	Spacer Assembly, 1-1/8" OD x 11/16" ID x 2.56"
37	1	9413-0121	Lip Deflector
38	1	9413-0122	Stop, Release lever Assembly
39	1	9413-0123	Hook Weldment, Tall Profile (Standard)
	1	9413-0127	Hook Weldment, Low Profile (Optional, not shown)
40	1	9414-0083	Base Weldment, 27 (Standard)
		9414-0084	Base Weldment, 24" (Optional, not shown)

PARTS

PowerStop A (Hydraulic) Parts Breakdown

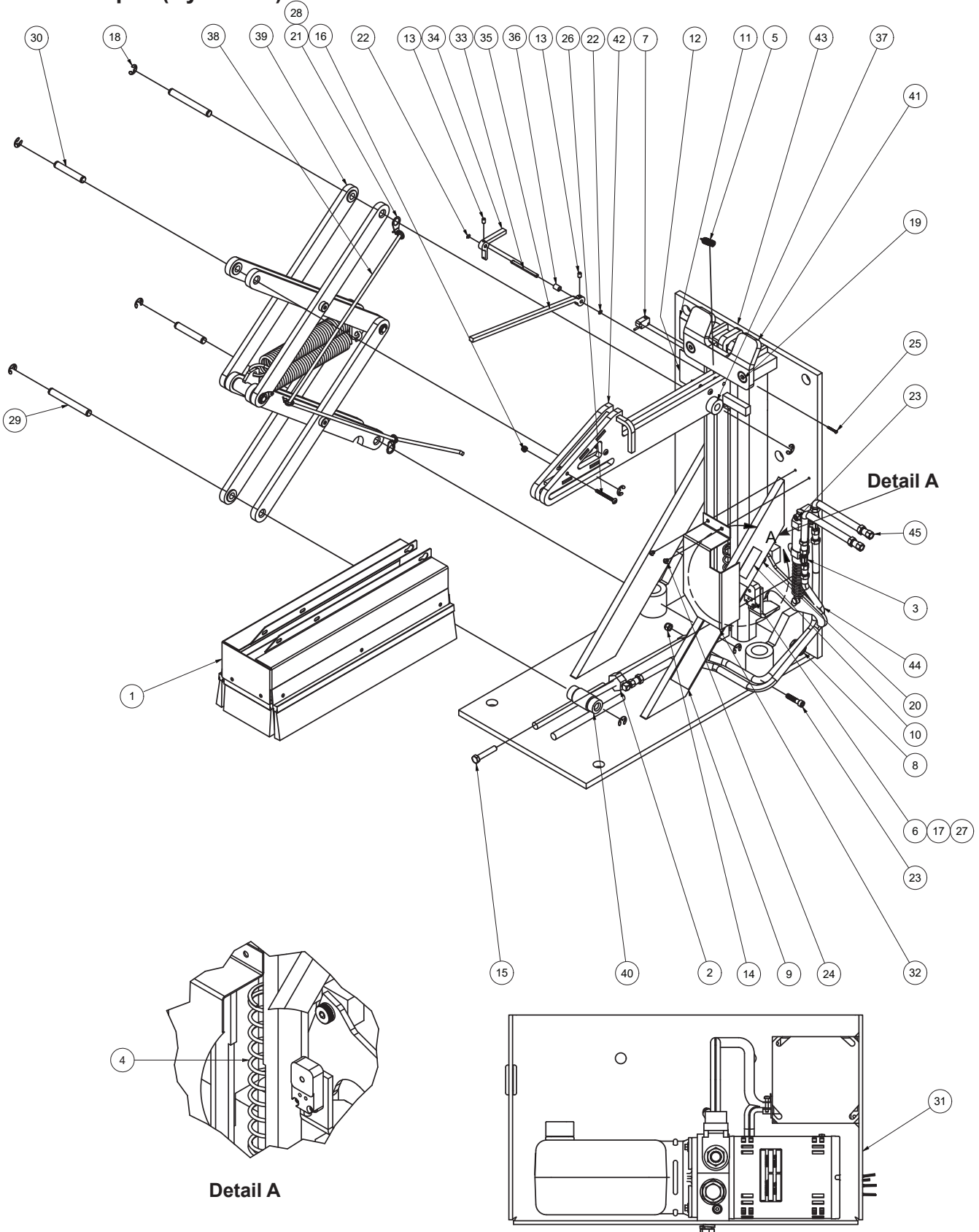

PARTS

Item	Quantity	Part Number	Description
1	1	0195-0052	Pstop, Debris Guard Assembly
2	1	0524-0064	Hydraulic Cylinder, 5-3/4" Stroke
3	1	0524-0102	Hydraulic Cylinder, 1" Stroke
4	1	0941-0018	Spring, Compression, 1.937" DIA X 7.402"LG,. 138 Wire
5	1	0941-0021	Spring, Extension, SS, 0.45" DIA X 1.76" LG 0.059 Wire DIA
6	1	0961-0538	Prox SW,AC,Flat, NO,20-250VAC
7	1	0961-0614	Prox Switch, RIG Sensor
8	1	1431-0239	Connector, Tubing, 1/2", Metal
9	1	1751-0444	Decal - Poweramp/PowerStop
10	1	1751-0735	Decal, Made In Usa
11	1	1751-1252	Decal, Pinch Point
12	1	1751-1290	Decal, Serial Number
13	2	2101-0032	Screw, SHSS,1/4-20 UNC X 3/8"
14	1	2101-0039	Nylon Lock Nut, 5/16-18 UNC
15	1	2101-0089	Screw, HHCS, 3/8"-16 x 2, Grade 2, Zinc Plated
16	3	2101-0151	Nylon Lock Nut, 10-24 UNC
17	2	2101-0156	Washer, Lock #8, Regular Split.
18	8	2101-0189	E-Ring, 1/2"
19	2	2101-0228	Screw, FSHCS, 1/2"-13 UNC x 1
20	1	2101-0335	Screw, Shoulder, 1/2" x 3/8", Zinc Plated
21	2	2101-0336	Washer, Tag Hole, 1/2", Stainless Steel
22	2	2101-0349	Retaining Ring, External, Zinc Plated
23	2	2101-0373	Screw, SHCS, 5/16"-18 X 1-3/8"
24	2	2101-0375	Screw, RHMS, TORX, #10-32 X 1/4"
25	2	2101-0376	Screw, RHMS, TORX, #4-40 X 7/8"
26	3	2101-0377	Screw, THMS, TORX, #10-24 X 2.00"
27	2	2101-0388	Screw, PHMS, #6-32 UNC x 5/8"
28	3	3051-0001	Cable Tie
29	2	9202-0042	Pivot Pin, Long, 0.499" DIA X 4.25" LG
30	2	9202-0043	Pivot Pin, Short, 0.499" DIA X 3.00" LG
31	1	9395-0414	Powerpack, Complete (Includes Valve Body and Cover)
32	1	9411-0065	Shroud, Release Cylinder
33	1	9411-0103	Pin, RIG Sensor Bar
34	1	9411-0104	Connection, RIG Sensor Bar
35	1	9411-0105	RIG Sensor Bar
36	1	9411-0107	Spacer, RIG Sensor Bar
37	2	9412-0161	Tube, 1-1/4" OD x 9/16" ID x 0.594"
38	1	9412-0289	Conduit, 1/4", Split Flex, 35" LG
39	1	9413-0062	Scissor Lift Assembly
40	2	9413-0069	Spacer Assembly, 1-1/8" OD x 11/16" ID x 0.53"
41	1	9413-0121	Lip Deflector
42	1	9413-0123	Hook Weldment, Tall Profile (Standard, not shown)
		9413-0127	Hook Weldment, Low Profile (Optional)
43	1	9414-0083	Base Weldment, 27
		9414-0084	Base Weldment, 24" (Optional, not shown)
44	2	9904-0097	Hydraulic Hose, 1/4 x 24, #4 JICF Swivel Ends
45	2	9904-0119	Hydraulic Hose, 1/4 x 96, #4 JICF Swivel Ends (Standard, not shown)
		9904-0098	Hydraulic Hose, 1/4 x 180, #4 JICF Swivel Ends (Optional, not shown)

PARTS

Scissor Assembly

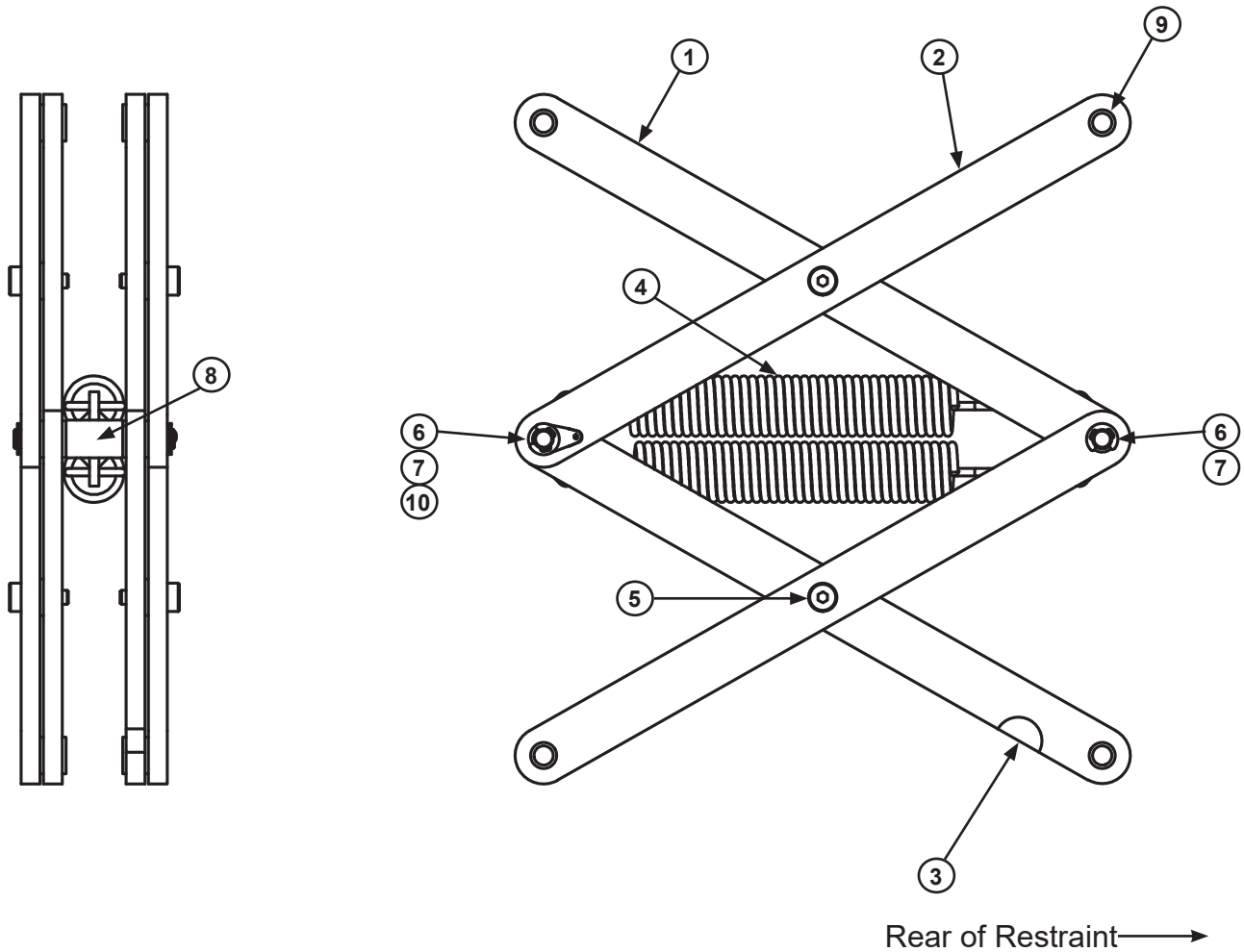

Item	Quantity	Part Number	Description
*	1	9413-0062	Scissor Lift Subassembly
1	3	9413-0063	Bar Assembly - Tapped W/Bushings
2	4	9413-0064	Bar Assembly - W/Bushing
3	1	9413-0065	Bar Assembly - Notched
4	2	0941-0011	Spring Extension
5	4	2101-0165	Socket Head Shoulder Bolt
6	4	2101-0189	E-Clip
7	2	9202-0042	Pin - Long
8	2	9413-0044	Spring Plate Weldment
9	16	9461-0006	Flanged Bearings
10	1	2101-0336	Washer - Tag Hole

Cantilever Brackets

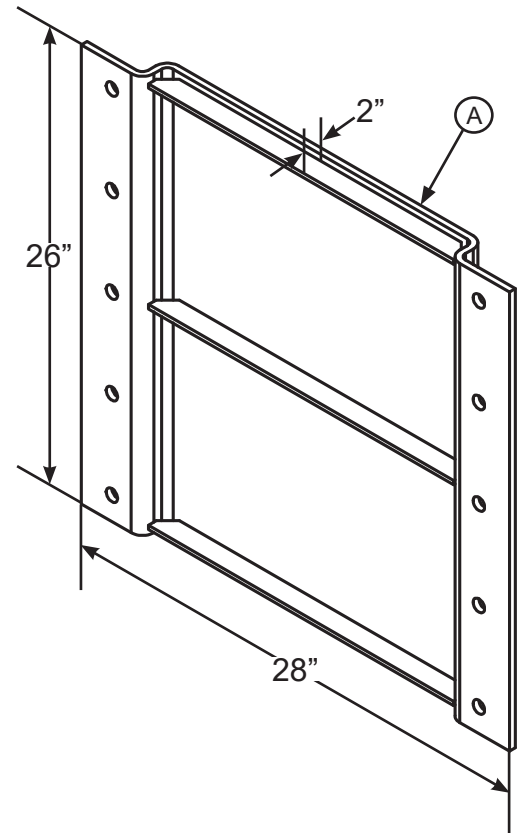
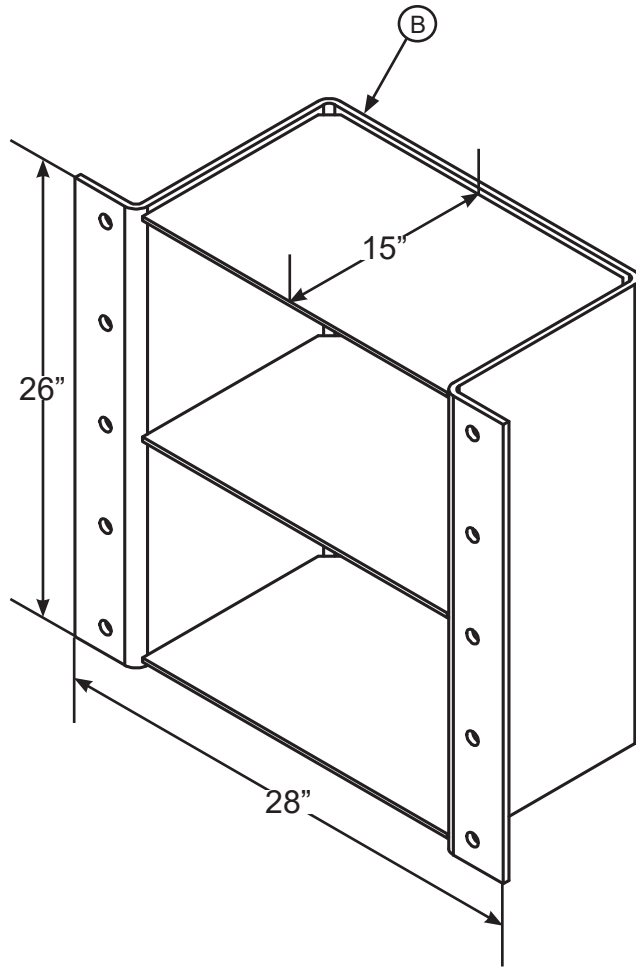

Note:

- 2" and 15" brackets shown for visual reference.

Item	Part Number	Projection
A	9703-0005	2"
	9703-0009	3"
	9703-0004	4"
	9703-0011	5"
	9703-0010	6"
	9703-0012	7"
	9703-0003	8"
	9703-0013	9"
	9703-0002	10"
	9703-0014	11"
	9703-0001	12"
	9703-0015	13"
	9703-0017	14"
B	9703-0016	15"

PARTS

Powerpack Assembly

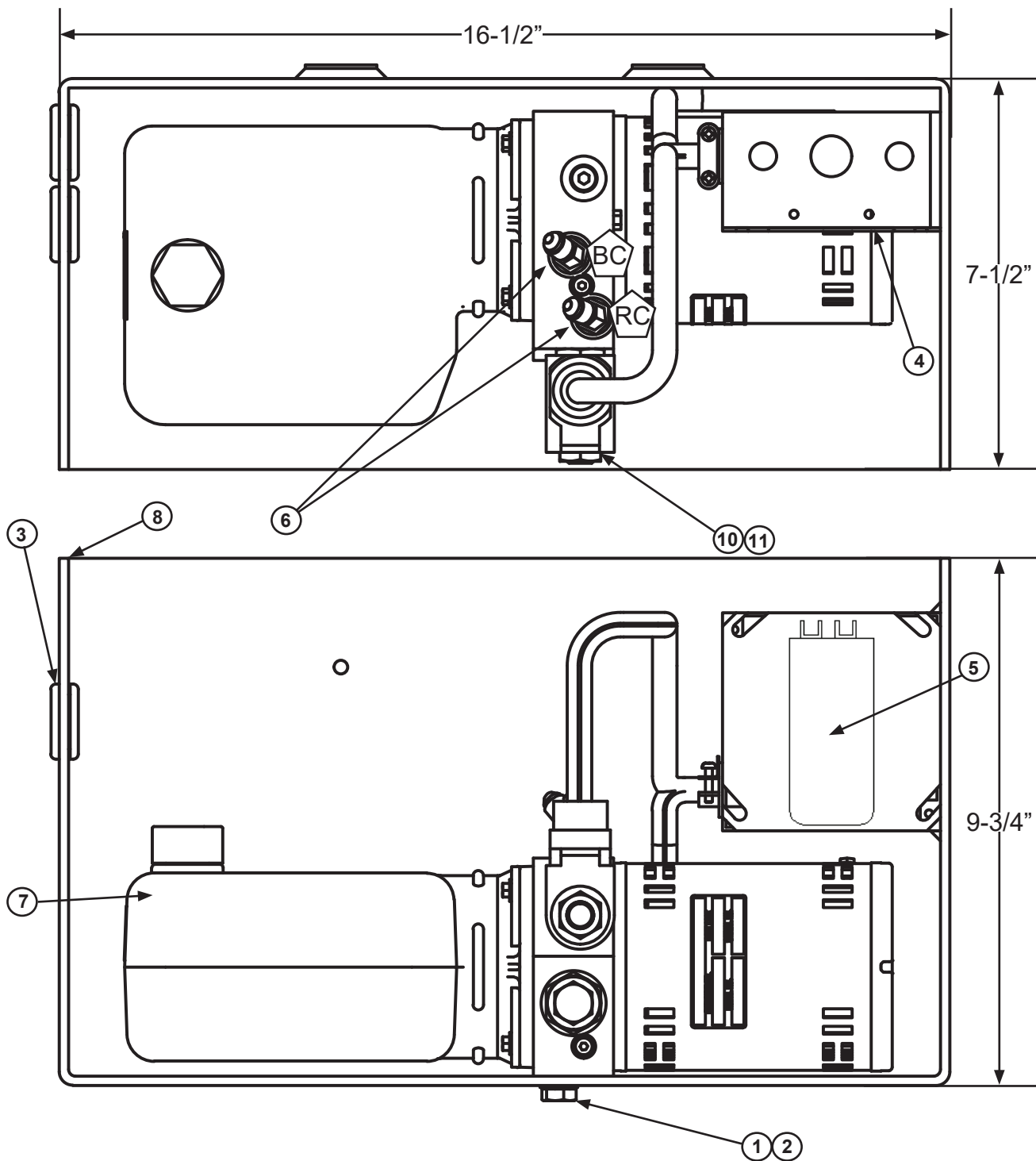

Note:

4.8-5.2 FLA (Full Load Amperage)

BC: Blind End of Cylinder

RC: Rod End of Cylinder

Powerpack Assembly

Item	Quantity	Part Number	Description
*	1	9395-0414	Powerpack, Complete (Includes Valve Body and Cover)
1	2	2101-0017	Screw, 3/8-16 UNC x 1, Grade 2, Zinc Plated
2	2	2101-0140	Lock Washer, 3/8
3	2	2401-0001	Grommet, 1-3/8 OD x 3/4 ID
4	1	2751-0016	J-Box Cover, 4 x 4
5	1	3051-0058	Capacitor - Motor Start, 66-77mf - 330V
6	2	9301-0221	Fitting, 45 Degree, #4 ORBM to #4 JICM
7	1	9391-0087	Powerpack, 1/4HP, 0.94GPM, 1-phase, 115v, 725 RV
8	1	9391-0012	Powerpack Mounting Weldment
9	1	9391-0013	Powerpack Cover
10	1	8581-0117	Valve, 4-Way
11	1	8581-0118	Coil, 115v
12	1	1751-0149	Decal, "No Step"

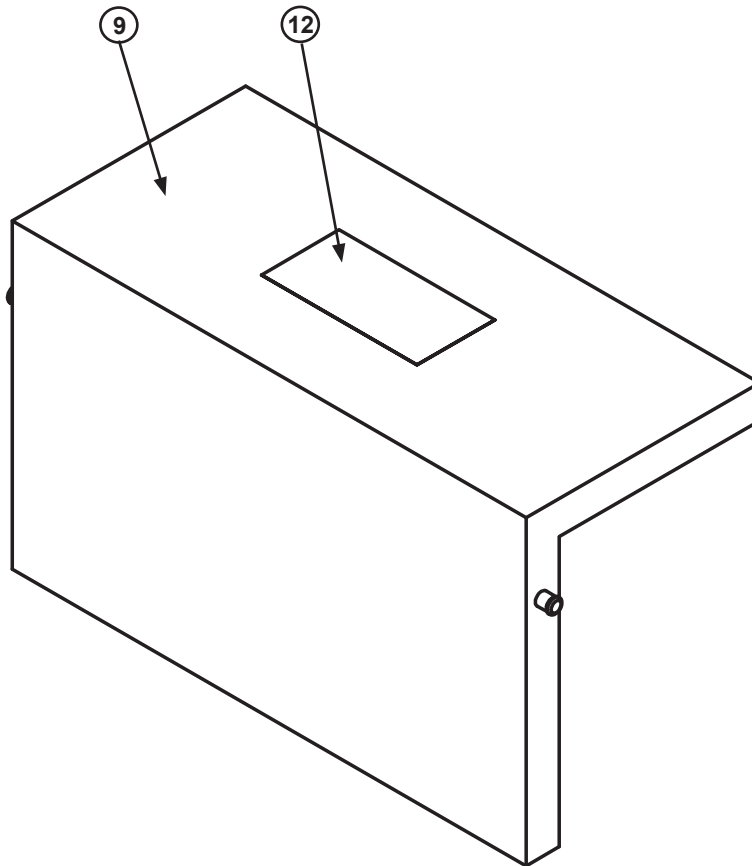

PARTS

PowerStop and Leveler Combination Valve Block

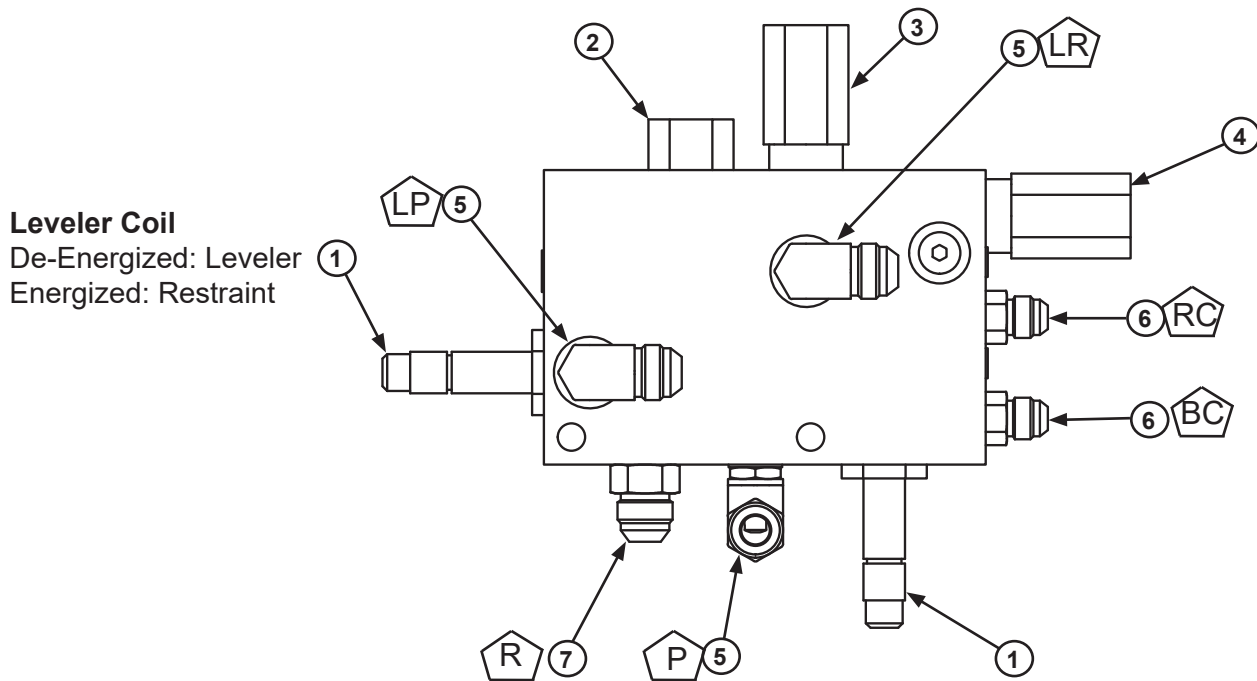

Leveler Coil
De-Energized: Leveler
Energized: Restraint

Restraint Coil
De-Energized: Lower
Energized: Raise

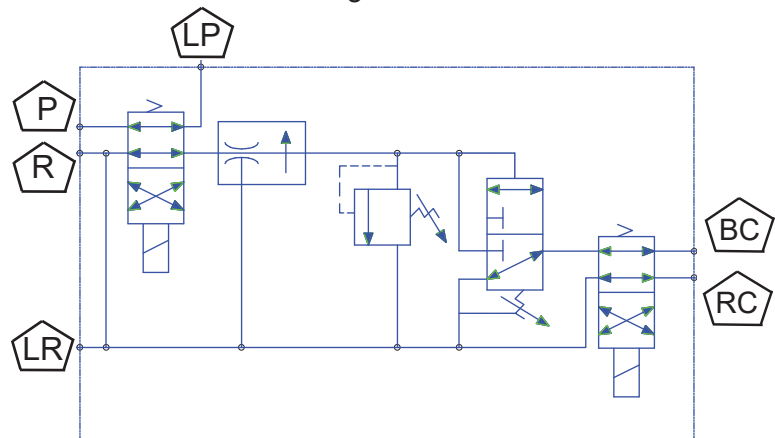

Item	Description
P	Pressure From Pump
R	Return To Tank
LP	Pressure To Logic Block
LR	Return From Logic Block
BC	Blind End of Cylinders
RC	Rod End of Cylinders

Item	Quantity	Part Number	Description
*	1	8583-0050	Valve Assembly (Contains 1-7)
1	2	8581-0011	Valve, 4-Way 2-Position
2	1	8581-0112	Valve, Flow Control 1 GPM
3	1	8581-0177	Valve, Flow Control 725 psi
4	1	8581-0114	Valve, Sequence
5	3	9301-0115	Fitting, Elbow, #6 ORBM to #8 JICM
6	2	9301-0135	Fitting, Straight Thread, #4 ORBM to #6 JICM
7	1	9301-0111	Fitting, Straight Thread, #6 ORBM to #8 JICM
8	1	8581-0004	Coil, 115v (Not Shown)

OSLA (Outside Light Assembly)

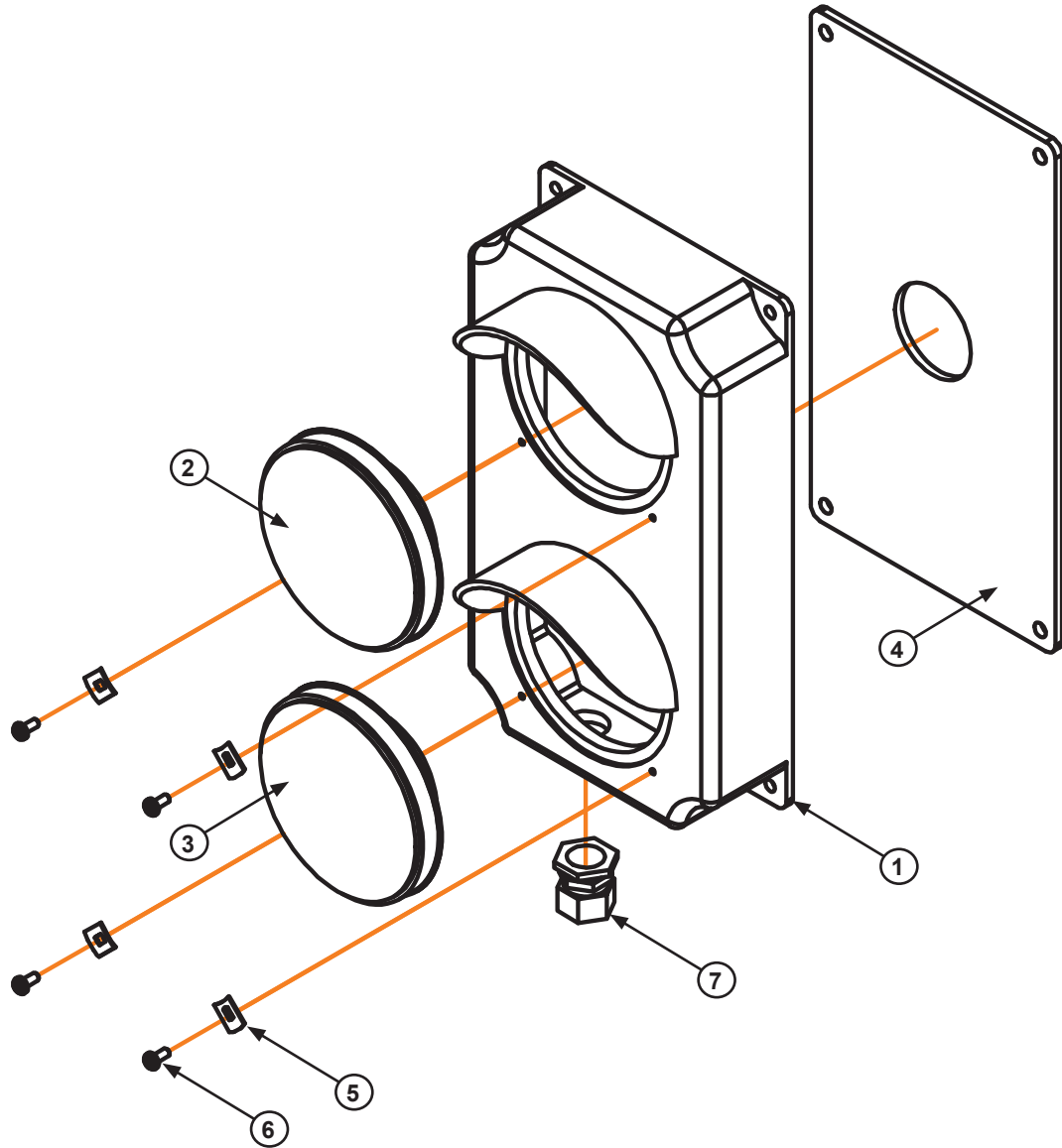

Item	Quantity	Part Number	Description
1-7	1	3055-0011	Complete Light Housing, Yellow Plastic, With 12v LED Lights*
1	1	3051-0002	Light Housing Only, Yellow Plastic
2	1	3051-0147	Red LED Lens/Housing/Circuit Assembly, 12v
3	1	3051-0149	Green LED Lens/Housing/Circuit Assembly, 12v
4	1	3051-0068	Mounting Gasket
5	4	3051-0105	Clip, Lens Holding
6	4	3051-0104	Screw, Lens Holding
7	1	*	Conduit Fastener, 3/4" x 3/8"

*Provide vehicle restraint serial number when e-mailing, calling or faxing orders.

PARTS

Signs



A



C



B

Item	Part Number	Description
A	1751-0033	Outside Sign, Pull In/Out
B	1751-0034	Outside Sign, Pull In/Out (Mirror Image)
C	1751-0036	Inside Sign, Enter On Green Only

Customer Information

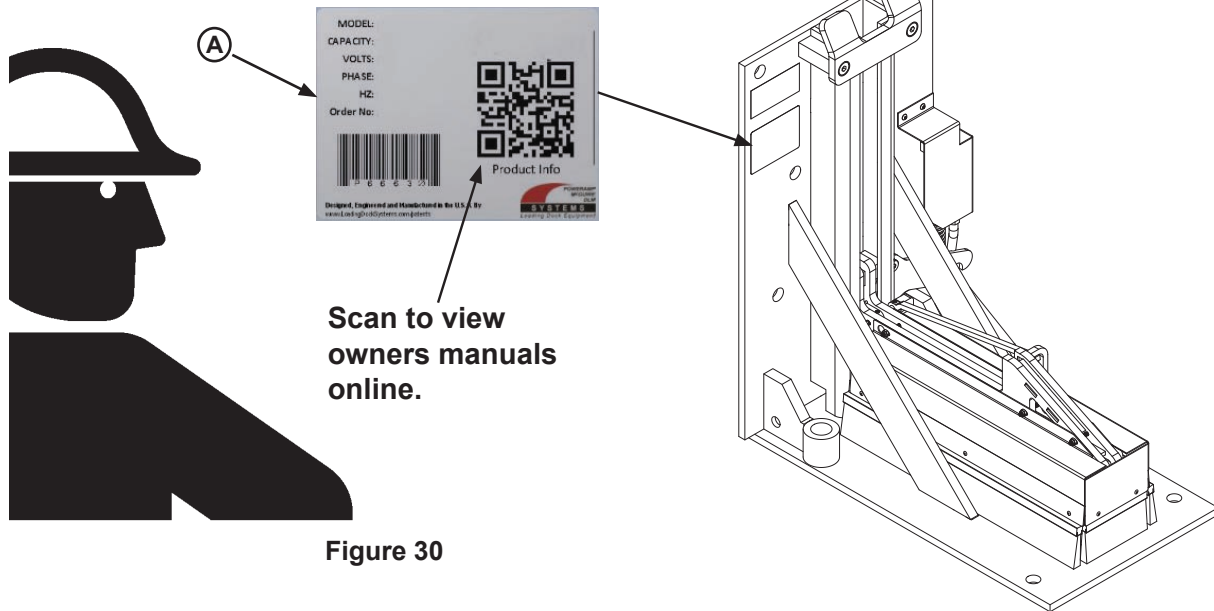

Figure 30

NOTE: Refer to Figure 30 for orientation of restraint and example of decal.

The RESTRAINT model/serial number decal (A), is located on the left side of the rear vertical track.

When you receive your new equipment, write down the model and serial number in the form provided. This will help ensure safe keeping of the numbers in the event the model/serial number decal (A) becomes lost or damaged.

Also, write down Systems, LLC's order number, the company that installed the equipment, and the original owner's name. This will all help to identify the specific equipment if more information is required.

When ordering, use part numbers and description to help identify the item ordered. Do not use "item" numbers. These are only for locating the position of the parts. Always give MODEL NUMBER and/or SERIAL NUMBER.

For service, call or contact:

Systems, LLC
P.O. Box 309
Germantown, WI 53022

Phone: (800) 643-5424
Fax: (262) 255-5917

www.loadingdocksystems.com

<u>Dock Leveler Information</u>	
Model	_____
Serial No.	_____
Systems, LLC, Job No.	_____
<u>Vehicle Restraint Information</u>	
Model	_____
Serial No.	_____
Systems, LLC Order No.	_____
<u>Original Owner Information</u>	
Name	_____
Address	_____

<u>Installer Information</u>	
Name	_____
Address	_____

Date of Installation	_____

STANDARD PRODUCT WARRANTY

SYSTEMS, LLC warrants that its products will be free from defects in design, materials and workmanship for a period of one (1) year from the date of shipment. All claims for breach of this warranty must be made within 30 days after the defect is or can with reasonable care, be detected. In no event shall any claim be made more than 30 days after this warranty has expired. In order to be entitled to the benefits of this warranty, the product must have been properly installed, maintained and operated in accordance with all manufacturer's recommendations and/or specified design parameters and not otherwise have been subject to abuse, misuse, misapplication, acts of nature, overloading, unauthorized repair or modification, application in a corrosive environment or lack of maintenance. Periodic lubrication, adjustment and inspection in accordance with all manufacturers' recommendations are the sole responsibility of the Owner/User.

In the event of a defect, as determined by SYSTEMS LLC, covered by this warranty, SYSTEMS LLC shall remedy such defect by repairing or replacing any defective equipment or parts, bearing the cost for the parts, labor and transportation. This shall be exclusive remedy for all claims whether based on contract, negligence or strict liability.

WARRANTY LIMITATIONS

THE ABOVE WARRANTIES ARE IN LIEU OF ANY OTHER WARRANTIES, WHETHER EXPRESSED OR IMPLIED, INCLUDING BUT NOT LIMITED TO ANY IMPLIED WARRANTY OF MERCHANTABILITY OR FITNESS FOR A PARTICULAR PURPOSE. SYSTEMS LLC AND ITS SUBSIDIARIES SHALL NOT IN ANY EVENT BE LIABLE TO ANYONE, INCLUDING THIRD PARTIES, FOR INCIDENTAL, CONSEQUENTIAL OR SPECIAL DAMAGES OF ANY KIND INCLUDING BUT NOT LIMITED TO, BREACH OF WARRANTY, LOSS OF USE, LOSS OF PROFIT, INTERRUPTION OF BUSINESS OR LOSS OF GOODWILL.